

UNITED STATES PATENT OFFICE.

AMBROSE G. WARREN, OF HOLYOKE, MASSACHUSETTS.

SAND-BLAST APPARATUS.

SPECIFICATION forming part of Letters Patent No. 649,782, dated May 15, 1900.

Application filed March 19, 1900. Serial No. 9,138. (No model.)

To all whom it may concern:

Be it known that I, AMBROSE G. WARREN, of Holyoke, in the county of Hampden and State of Massachusetts, have invented a new Improvement in Sand-Blast Apparatus; and I do hereby declare the following, when taken in connection with the accompanying drawings and the letters of reference marked thereon, to be a full, clear, and exact description of the same, and which said drawings constitute part of this specification, and represent, in—

Figure 1, a top or plan view of my improved hopper with the grate and screen and dust-pipes removed; Fig. 2, a side view of the same, indicating the dust-pipes and grate in position; Fig. 3, a vertical sectional view of the apparatus as arranged in a pit; Fig. 4, a broken sectional view illustrating the discharge-openings in one side of the hopper at the lower edge of the screen; Fig. 5, a broken sectional view illustrating the manner of securing the screen in position.

This invention relates to an improvement in sand-blast apparatus, and particularly to that class in which a sand-blast is employed for cleaning castings, and in which a grate is arranged in the floor upon which the castings are placed, and so that the sand from the blast and the material removed from the castings drop through the grating into a hopper, from which the dust is carried to a washer, the coarser material discharged from the hopper, and the sand carried to a separator. As usually constructed devices of this character require a deep space or pit below the floor to furnish sufficient room for the necessary mechanism, and these pits are liable to become filled with water in case the land is low, as frequently happens in foundries.

The object of this invention is a simple arrangement of hopper and mechanism whereby only a shallow pit will be required and by which the sand may be carried directly from the hopper to the separator; and it consists in the construction as hereinafter described, and particularly recited in the claims.

In illustrating my invention, I will omit the mechanism for producing the blast, the washer, and the means for producing an exhaust to carry the sand from the hopper to the separator, as these devices may be of any

approved construction and form no part of this invention.

In the floor A, I place the grate B, the ends of which rest on iron girders C on the tops of masonry walls D, which form the walls of a pit E. These walls also provide support for floor-beams A'. Around the pit and resting on the edge of the walls D are angle-irons F, to which are attached the four sides of a hopper G, which are preferably formed from sheet-iron, the said slides sloping inward and downward to the base H, which, if desired, may be supported on a suitable foundation H'. Through the base H a pipe I extends, which pipe leads to a separator. (Not shown.) In the base at the bottom of the hopper are openings a, which are adapted to be closed by a regulator J. In one side of the base is a hand-hole K, closed by a cover K', whereby access to the base may be had for clearing or other purposes. In one side of the hopper is a transverse slot L, which may be continuous or divided, as shown in Fig. 1, and this side of the hopper is reinforced by a strip M, which extends across the center of the slot, or across the space between the slits, if the slot is formed in two parts. Within the hopper and extending from one side downward to the slot L is a screen N, the upper edge of which rests upon the upper edge of the hopper, and it is formed with flanges n, which are turned against the sides of the hopper, to which they are clamped by means of strips O, which are bolted to the sides of the hopper and so as to clamp the flanges of the screen between the strips and the hopper.

In the side of the hopper above the slot L is a fender P, which will deflect the sand and screenings from the slot and so that they will first strike the screen. Resting upon the angle-irons F are supporting-rods Q, which hold dust-pipes R, more or less in number, which pipes are formed with openings r in their lower edges and provided on opposite sides with deflectors S. Preferably the edges of the flooring at the ends of the grates B are reinforced by angle-irons T and so that if the sand-blast is discharged against the ends of the flooring the impact will be taken by the metal angle-irons and therefore prevent the edges of the floor from being cut away.

A. G. WARREN.
SAND BLAST APPARATUS.

(Application filed Mar. 19, 1900.)

(No Model.)

Fig 1

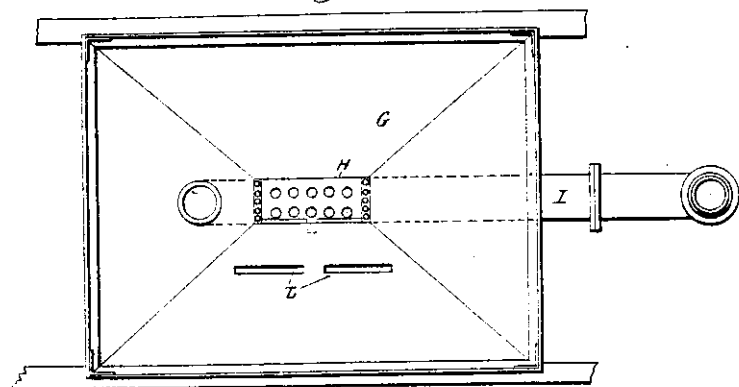

Fig 2

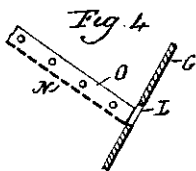
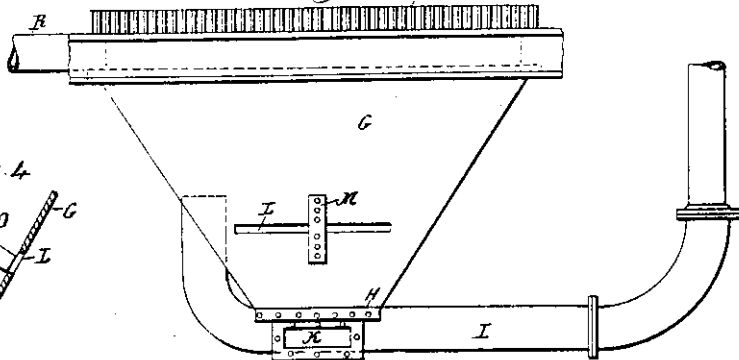

Fig 3

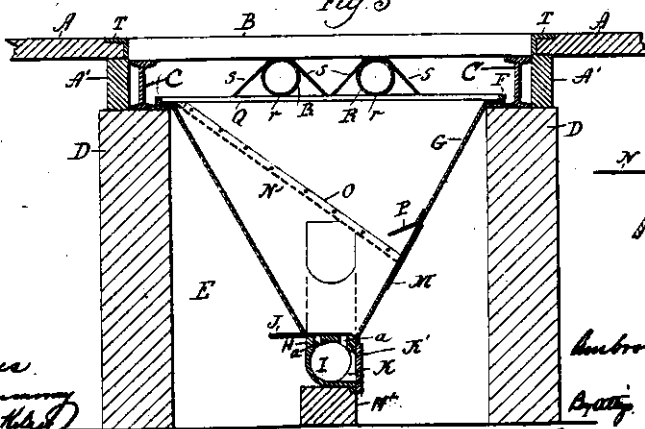
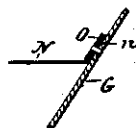

Fig 5



Witnesses
J. H. Shumway
John S. Hall

Andrew J. Davis
Attorney
Sumner & Carter

The operation of the device is as follows: The castings to be cleaned are placed upon the grate in the usual manner and a sand-blast discharged upon them. The sand from the blast and the material removed from the castings fall through the grate and the dust therefrom is drawn into the pipes R and with suitable blast carried to a washing apparatus. The heavier sand and material removed from the castings falls onto the screen, which is of suitable mesh to permit the sand to pass through it into the bottom of the hopper, while the screenings pass out through the slot L into the pit. The sand passing through the screen enters the base H and is carried through the pipe I under suitable pressure to a separator. A hopper thus arranged may be formed from sheet metal, and as the pipes employed are of ordinary cast-iron it is evident that the apparatus may be constructed at a very low cost for manufacture, and in arranging the hopper and screen therein, as shown, a comparatively-short hopper may be employed, and hence will not require a deep pit, in this way also reducing the cost of installation and maintenance.

Having fully described my invention, what I claim as new, and desire to secure by Letters Patent, is—

1. In a sand-blast apparatus, the combination with a hopper suitably supported below a grate, an inclined screen within the hopper,

and an opening in one side of the hopper in line with the lower edge of the screen, a base into which the hopper discharges, and a pipe leading from the said base directly to a separator, substantially as described.

2. In a sand-blast apparatus, the combination with a hopper suitably supported below a grate, an inclined screen within the hopper, and an opening in one side of the hopper in line with the lower edge of the screen, a base into which the hopper discharges, a pipe leading directly from the said base to a separator, and dust-pipes between the grate and hopper, substantially as described.

3. A sand-blast apparatus, comprising a pit, a hopper, the upper edges of which rest upon the side walls of the pit, a grate supported by said walls above the hopper, dust-pipes between the hopper and the grate, deflectors for said pipes, an inclined screen in the hopper, a slot in one side of the hopper in line with the lower edge of the screen, a base into which the hopper discharges, and a pipe leading from the said base directly to a separator, substantially as described.

In testimony whereof I have signed this specification in the presence of two subscribing witnesses.

AMBROSE G. WARREN.

Witnesses:

WILLIAM B. RUSSELL,
FREDERICK T. ROLFE.