

UNITED STATES PATENT OFFICE

2,249,677

APPARATUS FOR TREATING COIL SPRINGS

William H. Wallace, Detroit, Mich., assignor to
Eaton Manufacturing Company, Cleveland,
Ohio, a corporation of Ohio

Application July 11, 1940, Serial No. 345,019

7 Claims. (Cl. 29--90)

My invention relates to coil springs and the art of treating the same to increase their useful life in comparison with similar springs as heretofore manufactured. The invention is particularly applicable to helical compression springs such as are commonly used as valve springs in internal combustion engines and as suspension springs in automobiles and the like, which are particularly susceptible to failure due to fatigue resulting from the repeated application of stresses thereto.

It is known that the fatigue life of springs that are subjected to repeated flexing stresses may be increased by the cold working of the fibers at and near the surfaces of the metal, as by shot-blasting, and efforts have heretofore been made to apply this knowledge to the manufacture of coil springs by tumbling the springs in a barrel in which they are being subjected to a shot-blast. This method, however, has not been satisfactory because of lack of uniformity in the springs thus treated which results from the varying degrees of treatment that different springs received on account of the promiscuous manner in which different springs were presented to the blast of shot. In the case of larger coil springs such as those used in automobile suspensions, a better treatment has been obtained by conveying the springs through a fan-shaped shot-stream with the axis of each spring parallel with the planes in which the stream is fan-shaped, and rotating the springs about their axes while passing through the shot-stream. By this method the fibers on the outside of the coils are subjected to substantially uniform treatment but the fibers on the inside of the coils are treated to a much less extent because of the shielding effect of the portions of the coils which are directly in the path of the shot.

When a helical compression spring is put under compression the innermost surface fibers of the coils are subjected to an appreciably greater maximum stress than the fibers at the surface of the mean diameter of the coils, and the outermost surface fibers of the coils are subject to less maximum stress than the surface fibers at the mean diameter and very substantially less maximum stress than the innermost surface fibers.

It is one of the objects of the present invention to provide a method and apparatus for shot-blasting coil springs that will very substantially and uniformly improve the life of the springs by shot-blasting them in such a way that the effect of the shot-blasting on the fibers at and adjacent

the inner and outer surfaces of the coils will be at least substantially uniform, and preferably result in cold working the inner surfaces to a greater extent than the outer surfaces of the coils and thereby most effectively increase the strength and durability of the springs by subjecting the fibers, which are subjected to the maximum stresses, to the maximum amount of cold working.

In the accompanying drawings,

Fig. 1 is a side elevation of a helical spring of the type above referred to.

Fig. 2 is an end elevation thereof.

Fig. 3 is a diagrammatic perspective view of one form of apparatus for practicing my invention.

Fig. 4 is a perspective view of another form of apparatus for practicing my invention.

Fig. 5 is a diagrammatic view of a coil spring with its axis inclined to the direction of movement through the shot-stream to minimize the shielding of the inner surfaces of the coils.

Fig. 6 is a diagram showing the manner in which the springs are moved through the shot-stream in the apparatus illustrated in Fig. 3.

Fig. 7 is a diagram showing the paths of particular points on the coils through the shot-stream.

Referring to Figs. 1 and 2, the fibers at the points 10 represent the outermost fibers of the coils, those at the points 11 the innermost fibers, and those at the points 12 are on the mean diameter of the coils. When a spring of the type illustrated in Figs. 1 and 2 is compressed the innermost fibers, as at the points 11, are subjected to the maximum stress, and the outermost fibers, as at the points 10, are subjected to a lower stress, whereas the fibers at points 12 on the mean diameter are stressed less than those at the points 11 but greater than those at the points 10. Therefore, in order to obtain the most effective results by cold working or shot-blasting the surface fibers of the coils it is essential that the innermost fibers receive, at least, as much treatment as the outermost fibers and, since the innermost fibers are subjected to a greater stress than the outermost fibers, when the spring is stressed, it is desirable to give to the innermost fibers greater strength through an increased amount of cold working, and this is accomplished by the use of the method and apparatus which will now be described.

Referring to Fig. 3, 13 indicates a common form of shot-throwing wheel and 14 and 15 a pair of laterally adjustable spaced angle-iron

supports for the ends of the coil springs 16 which are to be shot-blasted. A belt 17 is carried by pulleys 18 and 19, at the opposite ends of the apparatus, and one of these pulleys will be power driven to move the belt 17 at the desired rate of speed. A series of suitably spaced fingers 20 are secured to the belt 17 and serve to move the springs 16 through the shot-stream which is indicated by the lines 21. In this connection it will be noted that the axis of the springs is substantially parallel with the axis of the shot-throwing wheel 13, and that the springs move through the shot-stream in a direction parallel to the planes in which the shot-stream is fanned out longitudinally of the belt 17. The angle irons 15 may be arranged horizontally or the right-hand end thereof, as viewed in Fig. 3, may be slightly elevated so that the springs will be rolled up-hill to some extent as they pass through the shot-stream.

Referring to Fig. 5, in which one of the springs 16 is illustrated, it will be noted that the axis of the spring is inclined to the direction of movement of the belt 17, which is indicated by the arrow 22, so that the lower half of the coils of the spring will be substantially parallel to the direction in which the spring moves through the machine. This is accomplished by having the fingers 20 arranged at an angle to the direction of movement of the belt 17. By thus positioning the springs with reference to their direction of translation through the shot-stream the inner surfaces of the lower half of the coils will be shielded a minimum amount by the upper half of the coils and, as will be noted from Fig. 6, the inner surfaces of the lower half of the coils will be directly exposed to the action of the shot which pass between the upper half of the coils.

Referring to Figs. 6 and 7, and particularly to Fig. 7, it will be noted that, as the springs move through the shot-stream, every point on the surfaces of the coils will move in a cycloidal path. For instance, the point *a* will describe the path indicated by the line 23, whereas the point *b* will describe the path indicated by the line 24. If we assume that the shot particles are discharged in a downward vertical direction by the wheel 13 it will be obvious that the point *a* will not be affected by the shot-stream until it moves to the point 25 which is at the intersection of the path 23 with the horizontal plane 26 through the axis of the coil. In other words, the point *a* will not be subjected to the shot-stream until the spring has rolled one-fourth of a revolution. In a similar manner the point *b* on the inner surface of the coil will not be affected by the shot-stream until it reaches the point 27 where the path 24 intersects the plane 26.

After passing the intersection 25 the point *a* will, theoretically, be subjected to the shot-stream while the spring is making a half revolution which will carry the point *a* over to the intersection 28 of the path 23 with the plane 26. While the point *a* is moving from the intersection 25 to the intersection 28 the point *b* will move from the intersection 27 to the intersection 29 of the path 24 with the plane 26. Since the point *a* moves from the intersection 25 to the intersection 28 in the same time interval that the point *b* moves from the intersection 27 to the intersection 29, it is obvious that the point *a* will be carried through the shot-stream at a much higher velocity than that of the point *b* and, because the point *b*, on the innermost surface of the spring, moves through the shot-

stream more slowly than the point *a* on the outermost surface it will be subjected to considerably more shot-blasting, while passing through any particular section of the shot-stream, than will the point *a* in passing through this same section of the shot-stream. Of course, on account of the shot-stream being fanned out, in the direction in which the springs are translated through it, the different portions of the stream strike the coils at different angles but, considering any particular section of the shot-stream, the fibers on the inner surface of the coils will be shot-blasted more than the fibers on the outer surface of the coils because of their slower movement through this section of the shot-stream. The practical effect of this is that the inner surface of the coils will be worked, by the shot-blast treatment, at least as much as the outer surface, and, for the reasons stated, will probably be worked more and therefore will be given greater strength and durability because of the shot-blast treatment.

It will be apparent that, in addition to the foregoing beneficial results of this method of moving the coils through the shot-stream, all of the springs will receive a uniform treatment and with the result that there will be greater uniformity in the strength and fatigue life of the different springs.

The improvement in the fatigue life of springs by this improved method of shot-blasting is indicated by the following table of tests in which internal combustion valve springs approximately 1 1/8" in diameter and 2 1/8" long were alternately compressed and released until fracture occurred:

	Cycles for failure			Number of springs		
	#1	#2	#3	#1	#2	#3
40	40,000-49,999	11				
	50,000-59,999	13				
	60,000-69,999	3	1			
	70,000-79,999	2				
	80,000-89,999		1			
	90,000-99,999	3				
45	100,000-199,999	1	13			
	200,000-299,999		10			
	300,000-399,999		5			
	400,000-499,999					
	500,000-599,999		2			1
	600,000-699,999		1			1
	700,000-799,999					1
	800,000-899,999					
50	900,000-999,999					
	1,000,000-1,999,999					
	2,000,000-2,999,999					11
	3,000,000-3,999,999					10
	4,000,000-4,999,999					5
						3

The above table indicates the number of cycles of compression and release by the column headed "Cycles for failure." There were three series of tests and thirty-three springs were tested in each series. In column #1 the springs were in the "as coiled" condition or, in other words, ordinary springs that had been through all of the usual manufacturing operations except that they had not been shot-blasted after being formed. Column #2 relates to springs exactly the same as those in column #1 except that they had been shot-blasted by the barrel method hereinabove referred to. Column #3 relates to springs that were exactly the same as those in column #1 except they had been shot-blasted in accordance with my improved method herein described. These tests showed that most of the ordinary springs which had not been shot-blasted failed at between 40,000 and 60,000 cycles, whereas most of the springs that were shot-blasted by the barrel method failed at between 100,000 and

300,000 cycles, and most of the springs shot-blasted in accordance with my improved method failed at between 1,000,000 and 3,000,000 cycles. From these results it is apparent that my improved method of shot-blasting enormously increases the fatigue life of the springs and that, in comparison with springs which have not been shot-blasted the average life is increased about fifty times, and in comparison with the springs shot-blasted by the barrel method the life has been increased at least ten times.

Another form of apparatus in which my improved method may be practiced is illustrated in Fig. 4 in which a pair of spaced parallel rollers 30 and 31 are mounted in suitable bearings and rotated in opposite directions by suitable power means. Between the rollers 30 and 31 there is a belt 32 which passes over pulleys 33 and 34, one of which may be driven by any suitable power means. The springs are arranged on the rollers as shown at 35 and are moved longitudinally of the rollers 30 and 31 by fingers 36. The shot-throwing wheel is indicated at 37 and the stream of shot at 38. In this case the wheel 37 rotates on an axis that is parallel with the axes of the rollers 30 and 31. The shot-stream is fanned out in planes at right angles to the rollers 30 and 31 sufficiently to cover the full diameter of the spring and may be of any desired width from a fraction of a length of spring to more than the length of a spring. The rollers 30 and 31 are rotated at sufficient speed to subject the entire spring to a substantially uniform amount of shot-blasting and the speed of the belt 32 is adjusted to move the spring through the shot-stream at such speed as will permit the desired amount of shot-blasting.

In the actual practice of my improved method, in an apparatus similar to that illustrated in Fig. 3 for shot-blasting springs of the kind referred to in the foregoing table, the shot-throwing wheel 12 was 19½" in diameter, 2½" wide, and revolved at 2300 revolutions per minute. The belt 17 traveled at the rate of about 12' per minute, and the wheel 13 discharged about 250 pounds of shot per minute, the shot used being steel particles about .020" in diameter, this shot being designated in the trade as #40.

While I have illustrated and described what I now consider to be preferred forms of apparatus for practicing my invention, it is understood that other forms of apparatus may be employed without departing from the spirit of my invention as defined in the appended claims.

Having thus described my invention, I claim:

1. In apparatus for shot-blasting the interior and exterior surfaces of coil springs, the combination of a track on which the springs are adapted to be rolled, the axes of the springs being at right angles to the direction of movement along said track, and means for discharging a stream of relatively fine shot at high velocity into the path of the springs as they roll along said track, said stream having a width axially of the springs of not less than the length of the springs and being fan-shaped longitudinally of said track so as to cover a space along said track having a length not less than the distance traveled by the springs in making one revolution.

2. In apparatus for shot-blasting the interior and exterior surfaces of coil springs, the combination of a track on which the springs are adapted to be rolled, the axes of the springs being at right angles to the direction of movement along said track, and means for discharging a stream of relatively fine shot at high velocity into the path of the springs as they roll along said track, said stream being fan-shaped longitudinally of said track and having a pattern in the path of the springs such as to cover an area the width of which is not less than the length of the springs and the length of which is not less than the distance traveled by the springs in making one revolution.

3. In apparatus for shot-blasting the interior and exterior surfaces of coil springs, the combination of a shot-throwing wheel adapted to throw a stream of shot which is fan-shaped in planes normal to the axis of rotation, and means for rolling the coil springs through said stream with their axes arranged transversely of said planes.

4. In apparatus for shot-blasting the interior and exterior surfaces of coil springs, the combination of a shot-throwing wheel adapted to throw a stream of shot which is fan-shaped in planes normal to the axis of rotation, supporting means for the springs extending through said stream of shot and on which the springs are rotated, the springs being arranged on said supporting means with their axes substantially parallel with the axis of said wheel, and means for moving the springs along said supporting means and through said stream of shot.

5. In apparatus of the class described, the combination of a track comprising a pair of opposed laterally adjustable angle bars arranged horizontally, flanges adapted to engage the ends of coil springs and on which the springs are adapted to roll, a belt arranged between said bars and having means for engaging the springs and roll them along said flanges, and a shot-throwing wheel arranged above said track and adapted to discharge a stream of shot having a width at least equal to the length of the springs and which is fan-shaped longitudinally of said track.

6. The herein-described method of substantially uniformly cold working the inner and outer surfaces of the convolutions of a coil spring, which consists in passing the spring through a stream of relatively small shot traveling at high velocity, the stream of shot being fan-shaped in planes substantially at right angles to the axis of the spring, and the spring being rotated on its axis while passing through said stream.

7. In apparatus for shot-blasting the interior and exterior surfaces of coil springs, the combination of a shot-throwing wheel adapted to throw a stream of shot which is fan-shaped in planes normal to the axis of rotation, rotatable means extending through said stream of shot and on which the springs are arranged and rotated with their axes substantially parallel with the axis of said wheel, and means for moving the springs along said rotatable means and through said stream of shot.

WILLIAM H. WALLACE.

July 15, 1941.

W. H. WALLACE

2,249,677

APPARATUS FOR TREATING COIL SPRINGS

Filed July 11, 1940

2 Sheets-Sheet 1

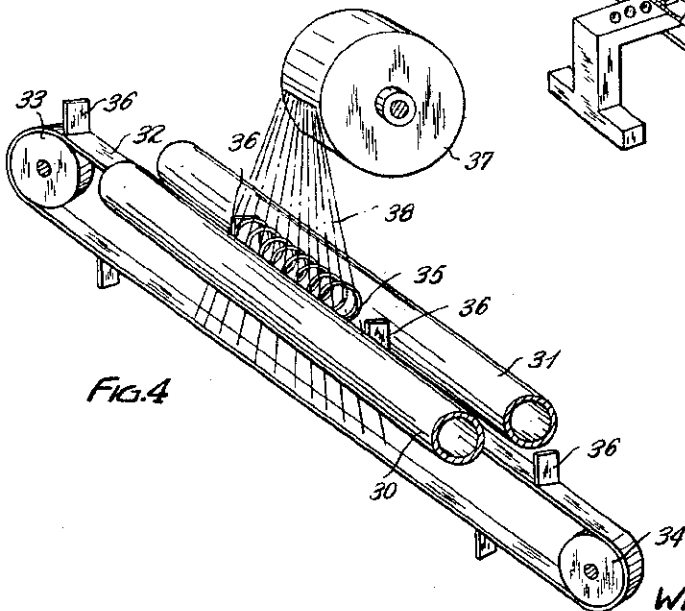
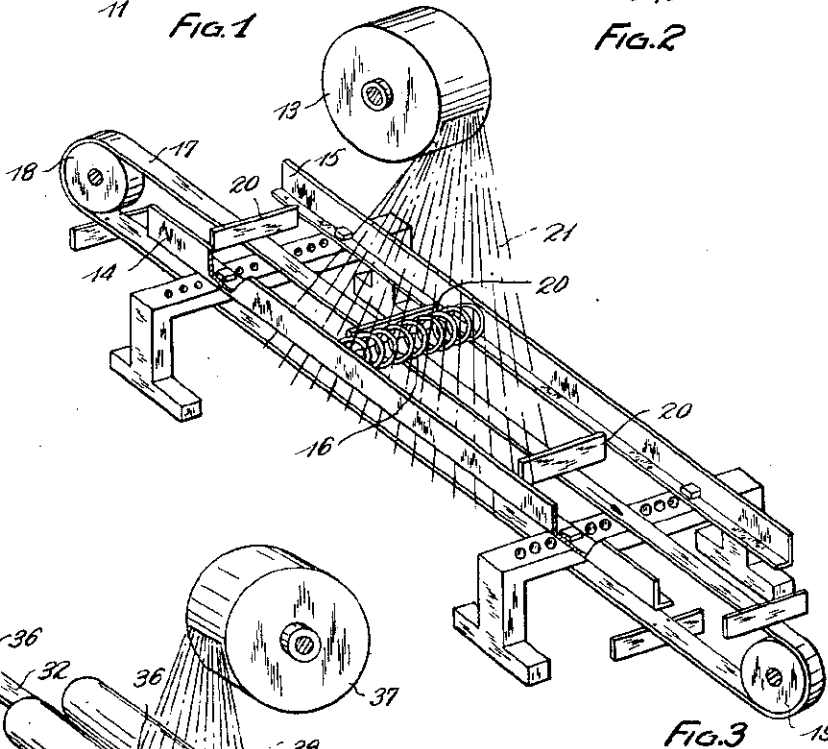
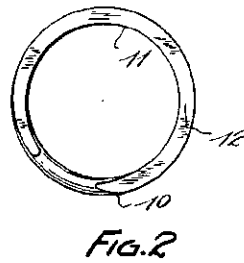
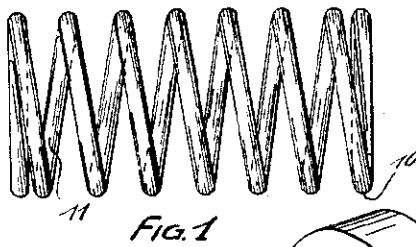

BY

INVENTOR.

WILLIAM H. WALLACE

Kwis Hudson & Kent
ATTORNEYS

July 15, 1941.

W. H. WALLACE

2,249,677

APPARATUS FOR TREATING COIL SPRINGS

Filed July 11, 1940

2 Sheets-Sheet 2

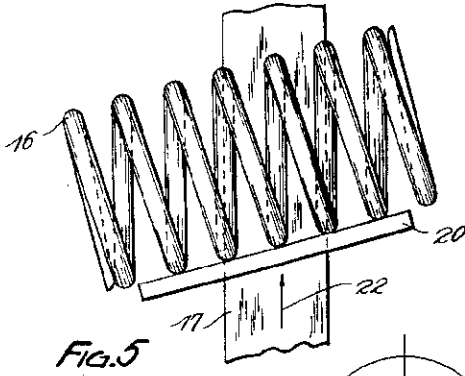

Fig. 5

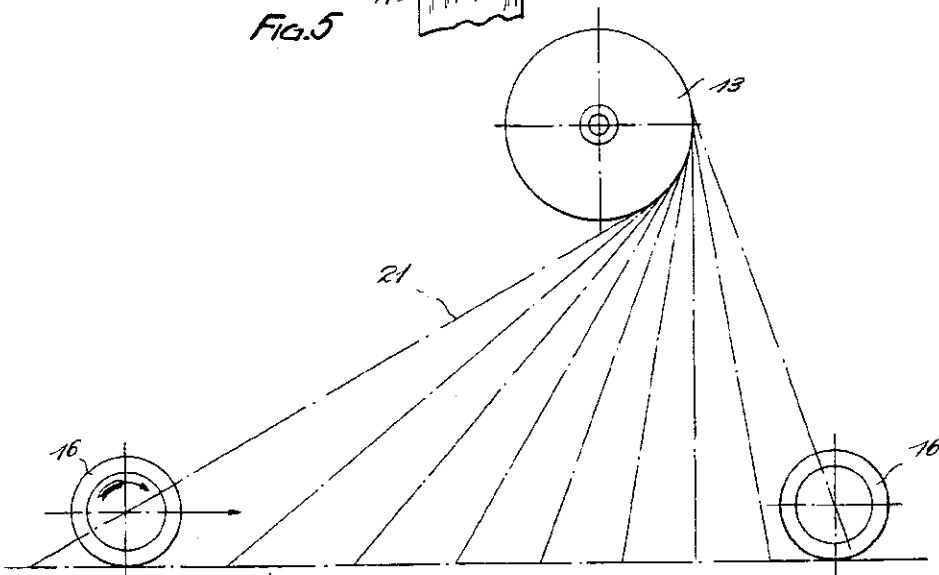

Fig. 6

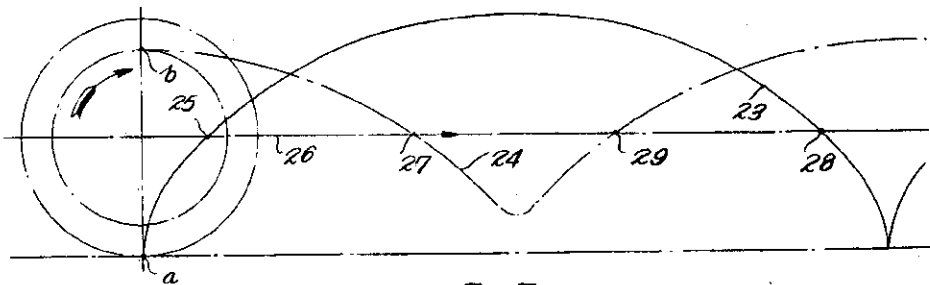

Fig. 7

BY

INVENTOR.
WILLIAM H. WALLACE
Kewis Hudson & Kent
ATTORNEYS