

1

2,850,162

SEPARATORS FOR PNEUMATICALLY CONVEYED AGGREGATE GOODS

Emil Widmer, Uzwil, Switzerland, assignor to Gebruder Buhler, Uzwil, Switzerland

Application August 10, 1955, Serial No. 527,600

Claims priority, application Switzerland August 11, 1954

8 Claims. (Cl. 209—134)

This invention relates to separators, and more particularly to separators for pneumatically conveyed aggregate goods wherein the goods are cleaned and sorted by the conveying medium.

Recent types of separators for cleaning and sorting pneumatically conveyed goods, such as grains or powdery substances, are based on the recognition that it is particularly advantageous to clean and sort the conveyed goods in a single step by means of air, to wit: by employing the principle of air sifting. The more economical systems use the conveying medium for cleaning and sorting of goods. In known devices of this character, the aggregate goods are separated from the air by means of an impact separator and thereupon permitted to descend as a thin veil from a chamber, and the conveying medium is guided therethrough to carry away the lighter components, such as dust, chaff, etc., thereby cleaning the goods and sorting the diverse components according to their specific weight. A serious disadvantage of such separators is in that the conveying medium, passing through the veil of goods, itself contains a certain quantity of dust or other impurities remaining therein from the conveying step. By passing through the veil of goods, these foreign particles again adhere to the larger grains and are not carried away by the conveying medium.

The present invention represents an improvement over such prior separators in that it provides a labyrinth system in which the impurities retained from the conveying step are separated from the conveying medium, and the clean conveying medium is then reintroduced through the separated aggregate goods to remove the remaining impurities therefrom.

The invention also provides a system in which the conveyed, separated and partially cleaned goods descend in a chamber with a mobile bottom wall to form a narrow aperture, and the goods, descending therethrough in a thin veil, are again subjected to the meanwhile purified conveying medium to remove the remaining impurities therefrom.

The invention further provides a system wherein the velocity of the conveying medium may be controlled by varying the cross-sectional area of the duct leading to the exhaust opening of the separator.

Still further, the invention provides a system wherein a baffle is installed below the impact separator to facilitate the sorting of separated goods and the removal of lighter impurities by the conveying medium.

An additional feature of the novel separator is in the provision of a dust collecting device at the exit end of the aspirating opening for removal of impurities and other lighter matter from the conveying medium.

The novel separator consists essentially of an airtight housing with an inlet for the conveying medium carrying the aggregate goods about to be cleaned and sorted in the separator, an impact separator chamber with a deflecting device and preferably a baffle member in-

2

stalled therein, the bottom of the chamber being pivotally attached to provide an elongated opening for passage of partially cleaned and sorted goods in a thin veil, a duct leading from the chamber with an arcuate portion and an adjustable passage therein. The conveying medium, usually and hereinafter referred to as air, carrying lighter impurities from the impact separator chamber, passes through the arcuate portion of the duct and the impurities following the outer peripheral wall thereof by centrifugal force enter the passage provided therein and are led through a conduit to the aspirating opening of the separator. The cleaned air is then introduced through the thin veil of goods descending from the chamber to remove any remaining impurities and undesirable lighter matter therefrom. Before entering the aspiration opening, the air is led through a duct portion whose cross-sectional area may be controlled to regulate the velocity of air.

Other features and advantages of the novel separator will be pointed out in the course of the following detailed description of one at this time preferred embodiment which is illustrated in the accompanying drawing, and the invention will be finally pointed out in the appended claims.

In the drawing,

Fig. 1 is a vertical section through the separator; and Fig. 2 is a somewhat schematic illustration of the device shown in Fig. 1 combined with a dust cyclone and a blower.

In Fig. 1, the illustrated separator 33, which is shown in vertical section, includes an inlet 1 leading into the impact separator chamber 3 with a deflector plate 2 in the path of goods 21, and a pivotable plate 5 as the bottom member of said chamber. Wall 7a of duct 7 is inwardly curved at its lower end 4 to form a simple baffle for goods 21 rebounding on plate 2. As illustrated, the heavier and larger particles carried by the air through inlet 1 rebound on plate 2 and are separated from the air in chamber 2 by descending onto the mobile bottom 5 which yields under a predetermined weight to form an elongated slot 6 between its free end and the lower extremity of wall 7b of duct 7. The air follows the route indicated by continuous arrow 22 and passes through the whirled goods 21 below member 4 before entering vertical duct 7, whose portion 11 is arcuate, carrying with it fine impurities 23, such as dust and chaff, which impurities by centrifugal force concentrate along the outer peripheral wall of the arcuate duct portion 11 to be absorbed into exhaust channel 13 through an adjustable passage 12, and to be thereupon aspirated through opening 10 by a blower 31 (see Fig. 2) or any other suitable device. As indicated, passage 12 is adjustable by moving flap 16 by means of a screw and hand wheel 17. The mass of air, now free from impurities 23, enters the left-hand vertical portion of channel 7 formed by walls 7c and 7d and passes below member 5 through veil 8 of goods 21 descending through aperture 6 to be deposited in the bottom of the separator 33. Any remaining lighter matter is removed from the veil 8 of goods 21 and is carried away by the air through duct 9 and exhaust opening 10. The cross-sectional area of duct 9 may be varied by screw and hand wheel 19 moving members 14 and 15, as indicated in dotted lines, to control the velocity of the air. An air lock 18 seals the separator and serves for removal of cleaned and sorted goods 21. A dust collector, such as a cyclone 34 (see Fig. 2), may be placed behind the aspiration opening 10.

It will be understood that the passage 12 may be provided at any point of the arcuate portion 11 of duct 7. Also, a different eddying device may be substituted

for the baffle member 4, and a counterweight 39, shown in broken lines in Fig. 1, or the like may replace spring 20 which compensates for the weight of the goods 21 deposited on plate 5, or a permanent slot 6 may be provided between members 5 and 7b. In the latter case, the baffle 4 may be omitted entirely.

The sucking passage 12 should be large enough to allow removal of all the impurities 23 therethrough and into channel 13. On the other hand, this passage 12 should be relatively small as compared with the cross-sectional area of duct 7 in order to introduce a large quantity of purified air through the veil 8 of goods 21.

In Fig. 2, conveying line 32, communicating with inlet 1 of the separator 33, aspirates the goods 21 directly from heap 37 through its intake 35. Adjacent to exhaust opening 10 is a dust cyclone 34 which is also connected to a blower 31 having an outlet 36. Blower 31 generates an underpressure in the system formed by the conveying line 32, separator 33 and the cyclone 34 causing the flow of air into intake 35 of line 32 and its escape through the outlet 36 of blower 31. The flowing air takes up the goods 21 from heap 37 and leads the material into separator 33 wherefrom the normal particles are discharged through the air lock 18. Smaller impurities flow through outlet 10 of separator 33 into the dust cyclone 34 to be separated from the conveying air and discharged through the air lock 38. Thus, the conveying air escaping through outlet 36 of blower 31 is clean.

As various changes and modifications in the details of construction, arrangement of parts and substitution of similar or equivalent elements may occur to persons skilled in the art, I do not desire to be limited to the exact details of the device shown and described, but only by the scope of the appended claims.

What is claimed is:

1. In a device for cleaning and sorting pneumatically conveyed aggregate goods having a housing, an inlet and an aspiration opening: an impact separator chamber, a deflecting member in said chamber in the path of pneumatically conveyed goods entering through said inlet opening, said chamber having an elongated aperture substantially in the bottom portion thereof for descent of aggregate goods separated from the conveying medium, a labyrinth duct for the conveying medium in said housing communicating with said chamber between said de-

flecting member and said aperture, said duct thereupon extending around said chamber and below said aperture and terminating at said aspiration opening, and means for separating impurities from the conveying medium in said duct in advance of the passing of said duct below said aperture in said chamber.

2. A device according to claim 1, further including means for varying said aperture in said chamber.

3. A device according to claim 1, wherein said chamber has a bottom wall, means pivotally connecting said bottom wall with said chamber and resilient means for urging said bottom wall against said chamber whereby to control said aperture in said chamber.

4. A device according to claim 1, wherein said duct includes an arcuate portion in advance of its passing below said aperture in said chamber, said arcuate portion having an aspirating passage in the outer peripheral wall thereof, and a conduit is provided for connecting said aspirating passage with said aspiration opening.

5. A device according to claim 4, further including means for varying said aspirating passage in said arcuate portion of said duct.

6. A device according to claim 1, further including a baffle member in said chamber below said deflecting member and above the communication of said duct with said chamber, said baffle member being in the path of conveyed goods descending from said deflecting member toward said aperture for eddying same, whereby the conveying medium entering said duct removes lighter matter therefrom.

7. A device according to claim 1, further including an air lock in the bottom of said housing for removal of conveyed and cleaned goods from said housing.

8. A device according to claim 1, further including a dust separating device for the cleaning medium in the proximity of said aspiration opening.

References Cited in the file of this patent

UNITED STATES PATENTS

9,261	Keeler	Sept. 14, 1852
300,044	Cord et al.	June 10, 1884
458,511	Whitmore	Aug. 25, 1891
474,354	Baker et al.	May 10, 1892
827,215	Comstock	July 31, 1906
1,945,771	Dahlstrom	Feb. 6, 1934
1,994,610	Huyett	Mar. 19, 1935

Sept. 2, 1958

E. WIDMER

2,850,162

SEPARATORS FOR PNEUMATICALLY CONVEYED AGGREGATE GOODS

Filed Aug. 10, 1955

2 Sheets-Sheet 1

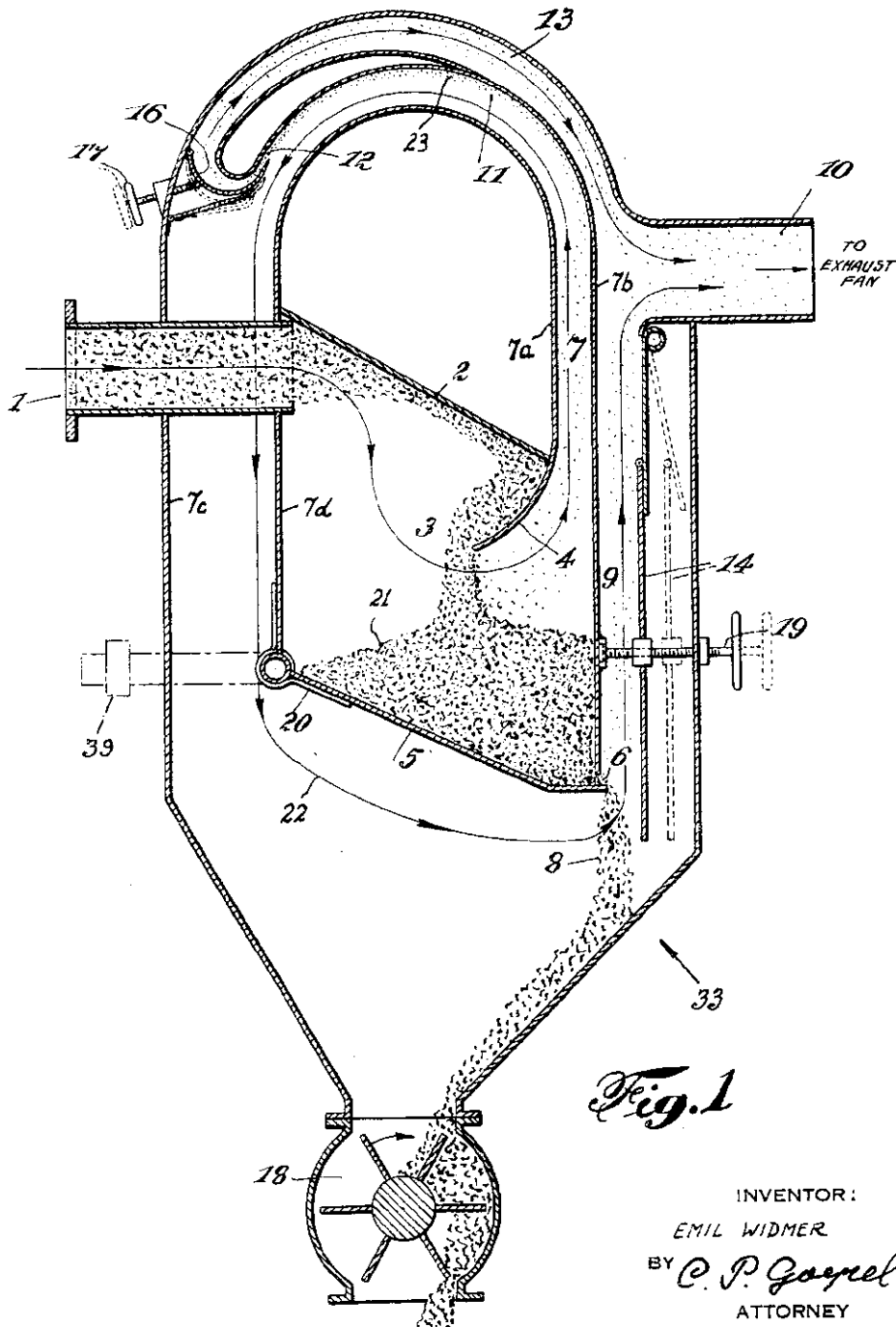

Fig. 1

INVENTOR:
EMIL WIDMER
BY *C. P. Gornel*
ATTORNEY

Sept. 2, 1958

E. WIDMER

2,850,162

SEPARATORS FOR PNEUMATICALLY CONVEYED AGGREGATE GOODS

Filed Aug. 10, 1955

2 Sheets-Sheet 2

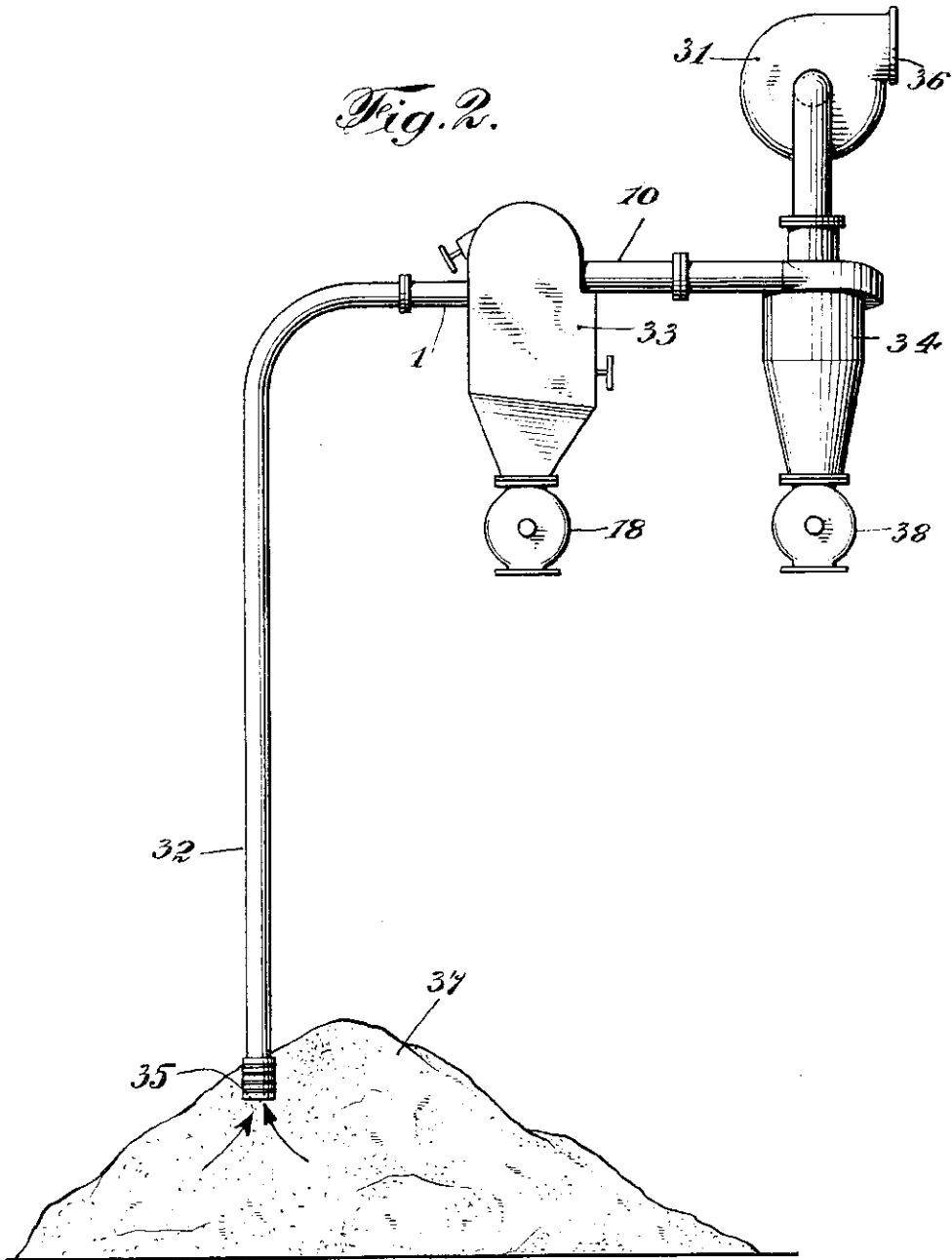

INVENTOR
Emil Widmer
BY *C. P. Gaepel*
his ATTORNEY