

1

2,732,666

CENTRIFUGAL BLASTING APPARATUS

George W. Powell, Hagerstown, Md., assignor to Pangborn Corporation, Hagerstown, Md., a corporation of Maryland

Application September 23, 1952, Serial No. 311,122

4 Claims. (Cl. 51-9)

The present invention relates to centrifugal blasting apparatus, more particularly to such apparatus as that shown in U. S. Patent No. 2,582,702, granted January 15, 1952, which apparatus projects a directional stream of blastant particles.

Among the objects of the present invention is the provision of novel apparatus having reduced maintenance problems.

Additional objects of the present invention include a novel centrifugal blasting apparatus suitable for use in substantially any orientation to provide a blastant stream directed in substantially any desired manner.

The above as well as still further objects of the present invention will be more clearly understood from the following description of several of its exemplifications, reference being made to the accompanying drawings wherein:

Fig. 1 is a side elevation partly in section of one form of centrifugal blasting apparatus in accordance with the present invention;

Fig. 2 is an enlarged detail view of the apparatus of Fig. 1 looking at it from the right-hand side of this figure;

Fig. 3 is a partly broken away sectional view of the apparatus of Fig. 1 taken along the line 3-3;

Fig. 4 is a vertical section of the drive shaft portion of the apparatus of Fig. 1;

Fig. 5 is a sectional view of the wheel portion of the apparatus of Fig. 1 taken along the line 5-5;

Figs. 6 to 15 inclusive are diagrammatic small scale views showing the operation of the apparatus of Fig. 1 under different conditions; and

Fig. 16 is a perspective view of a throwing blade of the apparatus of Fig. 1.

According to the present invention a centrifugal throwing wheel assembly includes a throwing wheel carried on one end of a rotatable shaft for rotation to tangentially project particles fed to the central portion of the wheel, the shaft journaled on one side of a generally flat base having an opening into which part of the wheel is fitted, and a housing is mounted on the same face of the base and encircles the portions of the wheel that extend on that side of the base, the wheel-carrying end of the shaft having an enlarged flange, and the wheel having a diameter larger than that of the flange and being secured to said flange, the housing having a shaft-admitting opening with a diameter large enough for the penetration of the flange, and a wear plate secured to the inner wall of the housing and partially covering said opening to define a second opening smaller than the flange but sufficient for the penetration of the balance of the shaft.

In addition the present invention includes the shaping of the face of the wheel engaged by the flange to provide a rib extending circularly around this face and projecting from it, and baffle rings within the housing and cooperating with the wheel to minimize the passage of blastant particles from the housing to the shaft journals, one of the rings closely surrounding the wheel edge adjacent the ribbed face and the other ring closely surrounding the rib. Preferably a tubular shaft enclosure fits over the

2

shaft, and is also secured to the base, the ends of the shaft-enclosure which communicates with the housing opening being provided with annular baffle ribs and the corresponding portions of the shaft carrying mating baffles that mesh with the baffle ribs and rotate with the shaft to assist in sealing the shaft journals from the blastant particles. The housing can also contain wear plates in the form of a set of side plates anchored in place and a top or cover plate as well as end plates set down on top of the side plates and held in place by their own weight.

The assembly also has a feed-control cup-shaped cage with an outturned marginal mounting lip and adjacent this lip an inwardly facing securing channel in which a spout anchor can be held. The feed to the cage can be a one-piece spout having an outlet passageway in the form of an outwardly flaring cone, a sealing collar around the passageway, and a set of perforated mounting lugs.

Where the individual throwing blades of the assembly are made relatively wide, the back of the blades is advisedly provided with a head-engaging first support rib as well as an outer marginal strengthening rib. For use in a plurality of different operative positions, the blastant feed spout passing through an opening in the housing wall adjacent the center of the wheel to supply blastant particles to the central portion of the wheel is adjustably held in place, a discharge directing cage between the central portion of the wheel and the bladed outer portion of the wheel is also adjustably held against the housing, and an indicator scale on the housing is held alongside a portion of the cage to indicate the director alignment, all adjustment being provided by a series of identical circularly disposed engagement elements formed as part of the housing.

Referring to the drawings, the apparatus of Fig. 1 shows a throwing wheel 20 having a shaft 30 rotatably mounted on suitable journals and carrying a runner head 32 upon which throwing blades 34 are mounted. The shaft 30 is shown as provided at one end with an enlarged flange 36 to which the head 32 can be firmly secured as by means of bolts penetrating through the flange and runner head from either side. The runner head is desirably of relatively massive construction so that unsymmetrical erosion of the throwing blades will not significantly unbalance the unit dynamically.

The blades 34 are equally spaced around the runner head and can be held in any suitable manner such as by the use of an enlarged dovetail edge 37 on one side of the blade, snugly engaging within a corresponding dovetail slot 39 in the face of the runner head. At their central ends, the blades are spaced apart to leave room for a feed assembly, and at their outer ends the blades, particularly where they are of substantial width, can be reinforced as by means of the ribs 41, 43. Rib 41 provides a support having a bracing edge 45 arranged to rest against the face of the runner head so as to provide a more substantial blade backing. Rib 43 strengthens the outer edge of the blade. Each blade is shown as held fixed in place by a pin 38 which is fitted into suitably aligned sockets 47, 49 in both the enlarged dovetail edge of the blade and the face of the runner head.

In the openings provided at the center of the runner head there is positioned a discharge-directing feed cage 40 which is of generally cylindrical or cup-shaped form and has an outwardly projecting marginal flange 42 which is suitably secured as by clamps 51 and bolts 74 and 76 to an external housing 44. The housing in turn is anchored to a frame 46 that forms part of the journals for shaft 30 and serves to securely hold the assembled parts together.

The bottom 48 of the cup-shaped cage has a central aperture 50, and its side is provided with a feed slot 52. Within the cage there is mounted an impeller 54 that in-

3

cludes a plurality of vanes 56 carrying at one end a cylindrical boss 58 which fits through cage opening 50 and by means of which it is fastened to the runner head, a central bolt 60 being shown in Fig. 1 as serving as threaded fastening. The interior of the impeller 54 is hollow, and is supplied with blastant particles as by means of the spout 62 which can be fastened to the housing 44 and which extends well into the cage 40 and close to the front opening of the impeller.

The spout 62 is shown as held in place by a set of three pins 61, two of which pass through aligned openings in a bracket 63 fastened to the housing, and a plate 65 formed integral with the spout. The third pin 61 is carried in a lip 67 opposite plate 65 on the outer edge of a collar 69 also formed integrally with the spout, and fits into an inwardly facing groove 71 formed by the radially directed marginal flange 42 and the stepped contour of the mouth portion of the cup-like cage 40. A rib 73 can be provided on this cage flange to show the normal position of the cage with respect to pin 61.

The cage also carries marks 75, 77 on opposite portions of flange 42, to cooperate with a scale 79 that is secured to housing 44.

The impeller 54 connected as above will be rotated along with the runner head. To assist in suitably driving the impeller, its cylindrical boss 58 may be provided with notches 64, one of which receives a projection such as the head of a bolt 66 fitted in the face of the runner head. If desired, one or more spacers may be inserted between boss 58 and the central portion of the runner head or the face of flange 36 as by completely drilling out the central portion of the runner head.

As shown in Fig. 1, the joint in blastant passageway from the spout to the cage can be equipped with a gasket 78 to minimize leakage of blastant particles at this point. FeH or asbestos or the like are suitable gasket materials.

The housing 44 is shown in Fig. 1 as secured to the frame or base plate 46 as by means of a set of bolts 91 threadedly received in the plate and holding down suitably positioned portions of an outwardly directed lower wall 53 forming part of the housing. Although only one bolt is shown in Fig. 1, these bolts extend around the entire housing periphery. On the shaft side of the wheel 20 there is secured to the housing a tubular enclosure 101 for the shaft 30. For this purpose the enclosure carries a clamping flange 103 through which clamping bolts 105 can be threadedly engaged to the adjacent portions of the housing. The remote end of the enclosure 101 can be ended at a seal 107 through which shaft 30 projects. To this projecting portion of the shaft a drive pulley 109 can be fixed as by means of key 111. The pulley is shown as held in place by washer 113 fastened to the shaft as by means of bolts 115 preferably offset from center and kept from backing off by safety wire passed through suitable apertures in the bolt heads and bound together. In the form shown the pulley 109 carries a set of five V-grooves 117 so that it can be driven by a corresponding number of V-belts.

The enclosure 101, which is enlarged at each end to accommodate bearings 121, 123, can be made of reduced size in its intermediate portion. The end of the enclosure adjacent the pulley can also be supported, as more clearly shown in Fig. 1, by outwardly projecting wings 125 integrally formed as part of the enclosure and bolted to angles 127 which are in turn secured to the base 46.

As more clearly shown in Fig. 4, bearing 121 is a twin roller bearing and is protected from the ingress of foreign particles by means of the meshed shields 131, 132. Shield 131 is fixed on shaft 30 and arranged to rotate with it, as by providing it with an internal opening which permits it to be pressed onto a suitable boss portion 135 of this shaft. Shield 132 is held fixed as by means of bolts 137 securing it to the enclosure 101. Each of the shields 131, 132 is formed with angular ribs that project out toward each other in interfingering relation to provide a

4

labyrinth-type seal through which particles such as flying bits of blastant must move before they can penetrate into the bearing 121. Some flying particles will reach the space around the shields inasmuch as shield 131 and all portions of the rotating shaft to which it is attached must have some spacing from the adjacent portions of the housing which is fixed. This spacing is indicated at 139. During operation, when the shaft 30 is rotating, foreign particles that make their way to these shields will be projected outwardly as by means of any contact with the rapidly rotating shield 131. Such particles will accordingly show a very small tendency to penetrate inwardly through the space 141 between the shields 131, 132. On the other hand, the particles will show a considerable tendency to fly outwardly in a radial direction. To accommodate this outward travel, enclosure 101 is also shown as provided with an escape aperture 143.

To further take advantage of the outwardly directing influence of the rotating shaft, the inner edge of shield 143 where it opposes the outer surfaces of the shaft, or a suitable ledge 145 of shield 131, is provided with a series of spaced grooves 147. When shaft 130 is rotated, those particles that work their way past the intermeshing ribs 133, 134 will tend to be trapped by the outwardly directed influences in one of these grooves 147 so that their progress past all the grooves is considerably hampered.

For improved operation the bearing 121 is provided with an externally communicating lubrication passageway 151 through which lubricants such as grease can be supplied at regular intervals to keep the bearing thoroughly lubricated. At the same time excess lubricant will be forced out from the bearing between the shields and help push back incoming foreign matter. To help in directing the excess lubricant through the space between shields 131, 132, an additional set of shields 153, 154 can be placed on the far side of the bearing 121. The additional shield structure is also provided with meshing ribs only slightly spaced from each other so as to provide added resistance to the outflow of lubricant.

Bearing 123 is also shown as protected by a set of cooperating shields including the shield plate 107 fixed to the enclosure and a pair of rotary shield washers 161, 162. The cooperating faces of these shield members are shaped to provide a labyrinth-type passageway for particles that may tend to come in from the pulley side of the enclosure 101. A set of grooves such as those indicated at 147 can also be provided in this shield.

To further guard against the penetration of foreign matter into the shaft bearings, the housing 44 is provided with special baffles around the opening to passageway 139. As more clearly shown in Fig. 1, the runner head 32 has its rear face shaped to provide an auxiliary rib 170 that extends around this face and projects in the direction of the shaft. At the same time there is affixed to the inner wall of housing 44 a pair of stationary guards 172, 174 which also extend in a generally angular or ring-like manner. Either or both of these fixed guards can be interrupted in the lower or discharge portion of the wheel. Fig. 3 for example shows guard 174 as uninterrupted, with guard 172 having about a 60 degree gap.

Guard ring 172 is positioned to overlap and lie very close to the back edge of the periphery of runner head 32. Guard ring 174 correspondingly coacts with the rib 170. The combination makes a dual baffle assembly so that flying particles which may be moving very rapidly in all directions in the housing are almost completely prevented from finding their way behind the runner head and into the space 139.

According to the present invention the housing 44 is also provided with a very convenient wear plate assembly. Thus, guard rings 172, 174 are directly held as by welding on wear panel sections 181, 182, 183 (see Fig. 3) which form a covering for the housing wall through which shaft 30 projects. These panels are secured to

5

this wall as by means of the bolts 185 and it will be noted that they do not cover all portions of the housing wall to which they are attached, but that they project out through the bottom of the housing to form an extension thereof. The opposing wall of the housing 44 is also provided with a similar set of wear panel members, a proper allowance being made for the penetration of cage 40 and the absence of any guard rings on this side.

The upper edges of the wear panel members are shaped to provide a generally convex top and flat sloping sides. At the lower portion of these sides, the wear panels are also provided with hooks 190 which can be bolted or riveted in place as shown. In these hooks is set a pair of end wear plates 192, which plates rest along the flat tapering edges of the side panel members. Plates 192 are not positively fastened down. Instead their upper ends are held under the edges of an arcuate wear lid 194 which spans the space between plates 192 and rests on the convex top of the side panels.

To help seal the margins of lid 194, it is provided on its concave lower surface with a pair of ribs 196, and at each end carries an offset overlap extension 198 that closely engages the upper end of adjoining plate 192. At the same time the upper or convex surface of lid 194 carries a longitudinally extending central rib 200 which can be provided with a pair of perforations as indicated at 202 to allow this rib to be readily gripped by an operator's fingers when the lid has to be inserted or removed. An additional transverse rib 204 can also be provided in the central portion of the lid top for strengthening purposes. The sealing of the lid margins is of considerable significance inasmuch as the blastant particles have an annoying tendency to find their way through the wear plate joints there and rapidly erode the housing walls.

Wear lid 194, as well as end plates 192, 192, merely rests in place under the influence of its own weight. However, to assist in keeping them from becoming dislocated during the operation of the assembly, particularly if it is to be tilted from the positions shown in Figs. 1 and 3, the lid 194 can be arranged to be fastened in place as by engagement with a cover 211 that closes the upper portion of the housing 44 and also provides convenient access thereto when desired. The cover is shown as held on the housing by means of one or more hinges 212 and manually operated clamps 214. In the form shown two such hinges and clamps may be provided symmetrically disposed at opposite ends of the cover 211 where they are secured to an angle iron 210 extending along the cover margin. Each clamp has a threaded shank 216 pivotally held as by pin 218 between angles 220 secured to the outside of the housing wall. The outer end of shank 216 is arranged so that it can be pivoted up in a slot 222 of a clip 224 held on the cover as by welding to angle iron 210 and threadedly receives a manipulatable handle 226. By drawing down the handle on a shank 216, it can be made to frictionally engage and hold down the clip 224, thereby locking the cover in closed position. To open the cover it is only necessary to rotate handles 226 so that they come away from clip 224, then permitting the loosened shank 216 to tilt downwardly around its pin 218. This leaves the cover unlocked so that it can be readily lifted out of the way. The hinges 212 can also be disassembled if desired.

As is more clearly shown in Fig. 1, cover 211 can carry gasket 230, conveniently held in place as by a mounting plate 232 fastened in place as by bolts 234. If desired, the lower ends of these bolts need be the only hold-down elements brought into contact with the upper portion, such as rib 200 of wear plate 194. In other words, when cover 211 is locked in place, it operates to securely hold the wear members 192, 192, 194 in their proper position.

A feature of the present invention is the fact that it so reduces the penetration of foreign matter into the shaft bearings that the life of these bearings is greatly

6

lengthened. In addition, it becomes possible to use the apparatus with the wheel tilted in any position so that the concentrated stream of blastant it provides can be oriented in any desired manner. Heretofore, excessive tilting of the wheel, as for example in the direction that permits blastant particles to fall down from the housing through the shaft enclosure could not be used without greatly increasing the wear on the bearings.

In addition to tilting the wheel rotation axis toward the vertical, the housing itself can also be tilted in any desired direction. Figs. 6, 7, 8, 9 and 10 show several examples of different housing positionings. It will be noted that in some of these positions the spout 62 would obstruct the view of the scale 79. For this purpose additional threaded openings 250 are provided on the outside face of housing 44 around the spout, and the scale 79 can then be moved to the opposite portion of cage flange 42 when necessary. As so relocated, the scale will cooperate with the second scale marker 77 provided in flange 42.

It is desirable to have the spout 62 positioned so that the abrasive particles fit into and readily fall through it under the influence of gravity regardless of the position of the apparatus. In other words, when the housing is tilted 45 degrees around the wheel rotation axis, as shown in Fig. 10 for example, it is advantageous to adjust the position of the spout so that it is substantially vertical. For this purpose the spout holding bracket 63 which is held by screws 74, 76 is shifted from the position shown in Fig. 2 to the position that it would have, as indicated in Fig. 10. In this new position the right-hand bracket-holding screw 76 fits into the threaded opening previously used for the left-hand screw 74, and the left-hand screw fits into an opening 250 covered by the central portion of scale 79. This relocation calls for the shifting of scale 79 which can then be held by its screws in a suitably selected pair of threaded openings 250 on the opposite side of the cage. Similar adjustments can be made for any of the positions shown in Figs. 6 to 10 inclusive. The throwing apparatus can also be used with the blastant stream directed vertically upwardly and, in fact, in any desired direction.

The apparatus of the present invention is also designed to be used with the wheel rotating in either clockwise or counterclockwise direction. The only changes needed for this purpose are the replacement of the runner head, the throwing blades and the scale 79. As so altered, the apparatus can then be used in all kinds of tilted positions as indicated above. The various positions of the housing corresponding to those of Figs. 6 to 10 inclusive are also shown in Figs. 11 to 15 inclusive for counterclockwise wheel rotation. The same general type of scale and spout adjustments are provided for.

Under some conditions of operation, as when the wheel rotation speeds are varied from normal, it is the usual practice to adjust the position of the direction controlling cage 40 so that the stream of blastant particles is discharged in the desired direction. Such adjustment involves a shift of generally only a few degrees and would then be indicated by a change in the portion of the scale to which one of the marks 75, 77 is directed. As so adjusted, the wheel can then always be placed in operation at the proper scale setting.

The various features of the invention need not all be used together. Thus, for example, the particular throwing blade construction shown in Fig. 16 is especially desirable only for the wide sizes of blades. Where the blades are less than about 4 inches in width, both of the ribs 241, 243 can be completely eliminated. In fact, the blades can be made with reversible faces so that they will be equally effective for either clockwise or counterclockwise rotation of the wheel. Two sets of pin sockets 49 can then be provided, one on each side of the dovetailed blade-receiving grooves 39 so that the pin fastening can be transferred from one side of the blade to the

other when the direction of wheel rotation is changed, without requiring shifting of the blades or any other changes. The inner face of the blade tongue 37 can be provided with a recess for receiving a bowed leaf spring to frictionally engage the floor of runner head slot 39 and help keep the blade from shifting.

The direction-controlling slot 52 in cage 40 can either extend axially with respect to the cage, or at some angle with respect to this axis. The tilting of the slot in this manner acts to spread out somewhat the blasting hot spot where the most effective blasting is performed by the discharged blastant stream. This is particularly suitable for blasting operations where it is not necessary to concentrate the blasting operation, but the blasting is intended to be effective over a generally large area, as where large articles are to be blasted over their entire surface, or masses of smaller articles are to be blasted in a tumbling drum. Instead of merely tilting the slot 52 in a uniform manner, it can be tapered along its length or formed in subdivided portions as shown for example in Reissue 20,538, granted October 19, 1937.

The wear plate assembly shown in the above construction is particularly desirable for maintenance purposes. Thus, a considerable portion of the scattered abrading particles that the wear plates protect the housing against, are directed radially of the wheel, so that they impinge against wear members 192, 192, 194. In accordance with the present invention, these wear members are readily removable and can be shifted in position so as to spread out the eroding effects. Thus, for example, if an examination should show that one of the plates 192 is suffering a considerable wear in one localized position, this plate can be removed and replaced in the following different manners:

1. Rotated 180 degrees in its own plane and returned to the same side it was taken from.
2. Rotated 180 degrees around its longitudinal axis and returned to the same side it was taken from.
3. Rotated 180 degrees around its transverse axis and returned to the same side it was taken from.
4. Rotated both 180 degrees around its transverse axis and 180 degrees around its longitudinal axis and returned to the same side it was taken from.
5. Rotated 180 degrees in its own plane and returned to the side opposite the one it was taken from.
6. Rotated 180 degrees around its longitudinal axis and returned to the side opposite the one it was taken from.
7. Rotated 180 degrees around its transverse axis and returned to the side opposite the one it was taken from.
8. Rotated both 180 degrees around its transverse axis and 180 degrees around its longitudinal axis and returned to the opposite side it was taken from.

In addition to the above, the wear lid 194 can be removed and replaced after rotating it end for end, thereby also distributing the localized wear. Furthermore, the ribs 196, 200 and 204 further operate to lengthen the life of the lid. It is noted that all these changes in wear plate positioning can be readily effected without the use of tools by merely unfastening and opening the housing cover 211 and then lifting out the particular plates and replacing them by hand.

For even greater wear plate life, the plates 192 can be arranged to be of square form in plan view so that they can also be turned 90 degrees in either direction in their own plane. This doubles the number of possible positions these plates can occupy.

Another feature of the present invention is the fact that in the arrangement shown the wheel-impelling shaft 30 can be readily removed from the housing 44. Thus, by simply unbolting and withdrawing the runner head 32 from flange 36, and wear plates 181, 182, 183, the entire shaft along with its enclosure 161 can then be withdrawn through the opening provided in the back wall of the housing. For this purpose, the enclosure 161 is

unfastened from the housing 44 as well as base 46 by unscrewing the anchoring bolts.

As many apparently widely different embodiments of the invention may be made without departing from the spirit and scope hereof, it is to be understood that the invention is not limited to the specific embodiments hereof except as defined in the appended claims.

What is claimed is:

1. In a centrifugal throwing wheel assembly for projecting blastant particles, a throwing wheel, a rotatable shaft carrying said wheel at one end for rotation to tangentially project particles fed to the central portion of the wheel, a generally flat base, said shaft being mounted for rotation on said base, said base having an opening into which part of the wheel is fitted, and a housing mounted on said base and encircling the portions of the wheel that extend beyond said base, said shaft having an enlarged flange, and the wheel having a diameter larger than that of the flange and being secured to said flange, the housing having a shaft-admitting opening with a diameter large enough for the penetration of the flange, and a wear plate secured to the inner wall of the housing and partially covering said opening to define a second opening smaller than the flange but sufficient for the penetration of the balance of the shaft.

2. In a centrifugal throwing wheel assembly for projecting blastant particles, a throwing wheel, a rotatable shaft carrying said wheel at one end for rotation to tangentially project particles fed to the central portion of the wheel, a generally flat base, said shaft being mounted for rotation on said base, said base having an opening into which part of the wheel is fitted, and a housing mounted on said base and encircling the portions of the wheel that extend beyond said base, said shaft having an enlarged flange, and the wheel having a diameter larger than that of the flange and being secured to said flange, the face of the wheel engaged by the flange being shaped to provide a rib extending circularly around this face and projecting from it, and generally annular baffle means within the housing and cooperating with the wheel to minimize the passage of blastant particles from the housing to the shaft journals, one of the baffle means closely surrounding the wheel edge adjacent the ribbed face and the other baffle means closely surrounding the rib for preventing the passage of outlying particles from both the peripheral and radial portions of said wheel.

3. In a centrifugal throwing wheel assembly for projecting blastant particles, a throwing wheel, a rotatable shaft carrying said wheel at one end for rotation to tangentially project particles fed to the central portion of the wheel, a generally flat base, said shaft being mounted for rotation on said base, said base having an opening into which part of the wheel is fitted, and a housing mounted on said base and encircling the portions of the wheel that extend beyond said base, said shaft having an enlarged flange, and the wheel having a diameter larger than that of the flange and being secured to said flange, the housing having a shaft-admitting opening to pass the shaft, and a tubular shaft-enclosure communicating with the housing opening and also secured to the base, the ends of the shaft enclosure being provided with annular baffle ribs and the corresponding portions of the shaft carrying mating baffles that mesh with the baffle ribs and rotate with the shaft to assist in sealing the shaft journals against the blastant particles.

4. In a centrifugal throwing wheel assembly for projecting blastant particles, a throwing wheel, a rotatable shaft carrying said wheel at one end for rotation to tangentially project particles fed to the central portion of the wheel, a generally flat base, said shaft being mounted for rotation on said base, said base having an opening into which part of the wheel is fitted, and a housing mounted on said base and encircling the portions of the wheel that extend beyond said base, said

9

shaft having an enlarged flange, and the wheel having a diameter larger than that of the flange and being secured to said flange, the sides of the housing opposing the wheel faces being covered by a first set of replaceable wear plates and these wear plates being bridged by a second set of replaceable wear plates that combine with the first set to completely shield the housing, said second set of plates including end plates and a top plate set down on top of the side plates and held in place by their own weight.

6

10

10

References Cited in the file of this patent

UNITED STATES PATENTS

1,953,566	Peik	Apr. 3, 1934
2,077,638	Minich	Apr. 20, 1937
2,108,005	Keefer	Feb. 8, 1938
2,118,832	Wean	May 31, 1938
2,341,559	Keefer	Feb. 15, 1944
2,352,588	Rosenberger	June 27, 1944

Jan. 31, 1956

G. W. POWELL

2,732,666

CENTRIFUGAL BLASTING APPARATUS

Filed Sept. 23, 1952

6 Sheets-Sheet 1

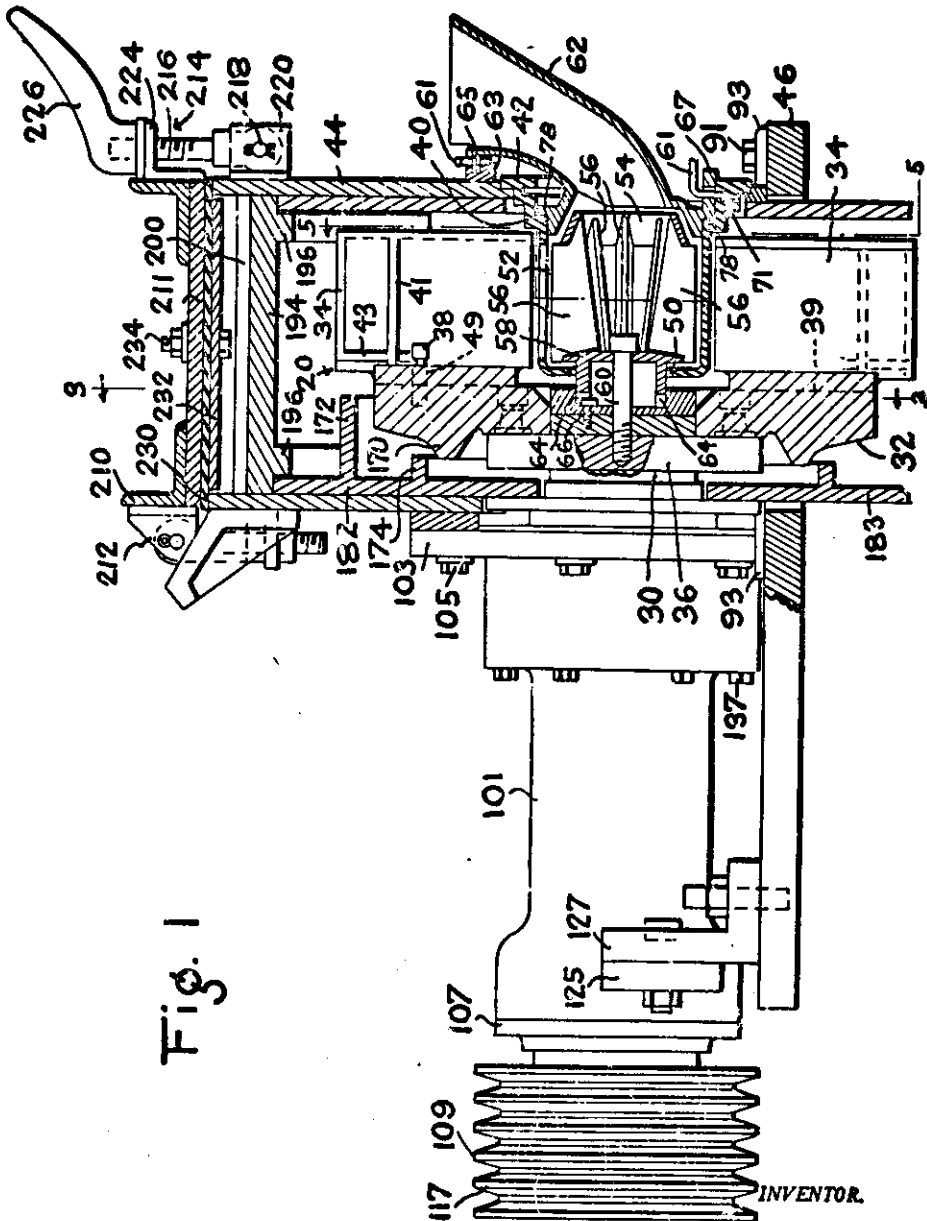

Fig. 1

INVENTOR.
GEORGE W. POWELL
BY
Connell and Harty
HIS ATTORNEYS

Jan. 31, 1956

G. W. POWELL

2,732,666

CENTRIFUGAL BLASTING APPARATUS

Filed Sept. 23, 1952

6 Sheets-Sheet 2

Fig. 2

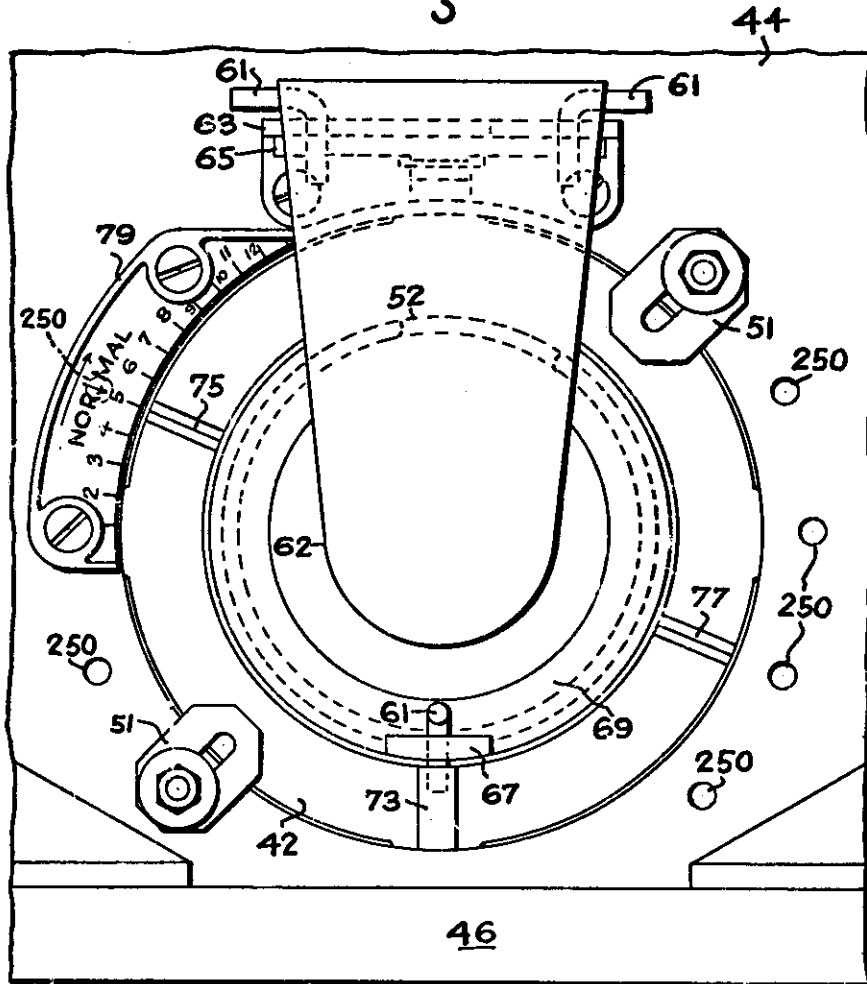

INVENTOR.
GEORGE W. POWELL

BY
Connolly and Futz
HIS ATTORNEYS

Jan. 31, 1956

G. W. POWELL

2,732,666

CENTRIFUGAL BLASTING APPARATUS

Filed Sept. 23, 1952

6 Sheets—Sheet 3

Fig. 3

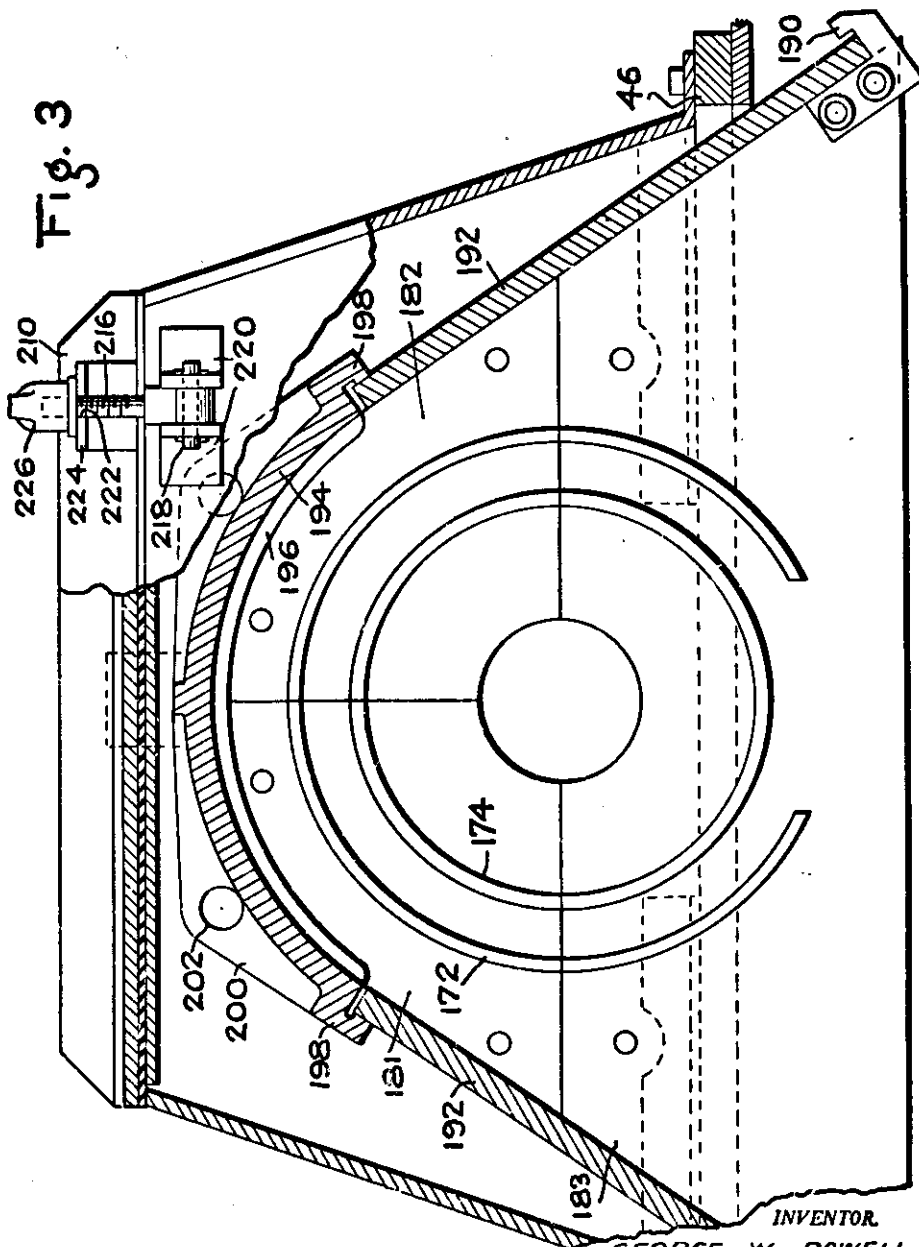

INVENTOR.
GEORGE W. POWELL
BY
Cornally and Hutz
HIS ATTORNEYS

Jan. 31, 1956

G. W. POWELL

2,732,666

CENTRIFUGAL BLASTING APPARATUS

Filed Sept. 23, 1952

6 Sheets-Sheet 4

Fig. 4

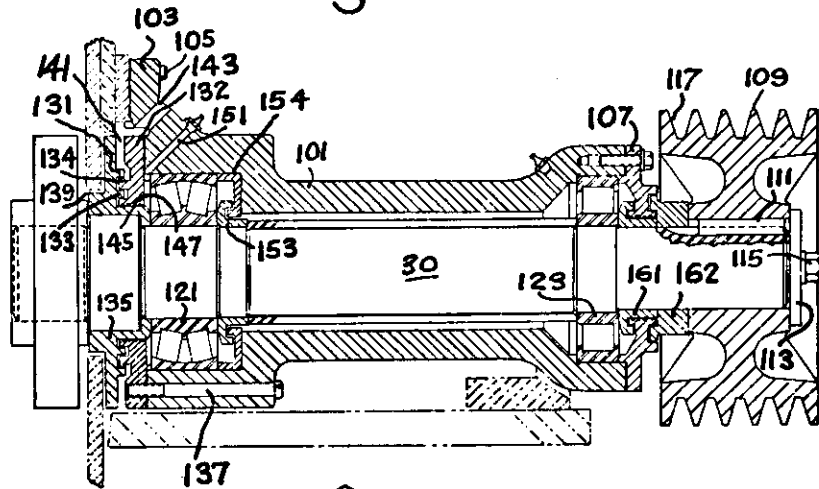
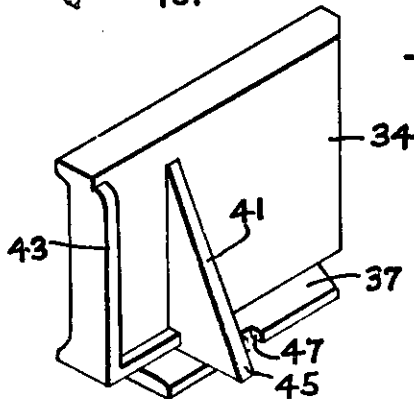

Fig. 16



INVENTOR,
GEORGE W. POWELL

BY *Conolly and Fitz*
ATTORNEYS

Jan. 31, 1956

G. W. POWELL

2,732,666

CENTRIFUGAL BLASTING APPARATUS

Filed Sept. 23, 1952

6 Sheets-Sheet 5

Fig. 5

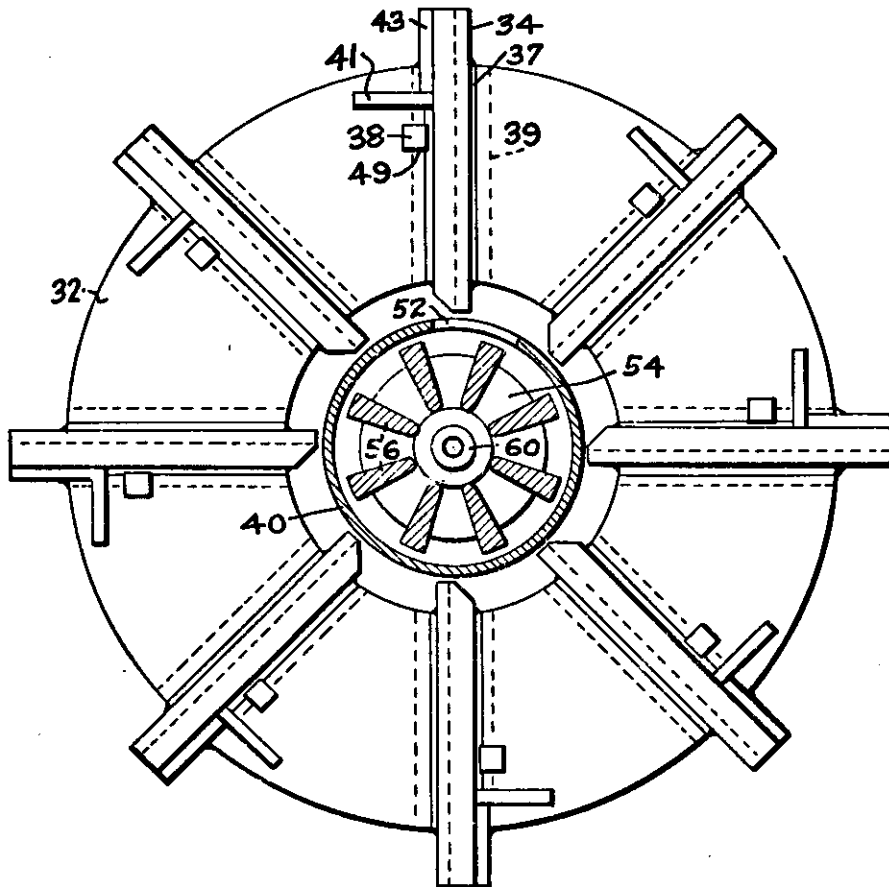

INVENTOR.
GEORGE W. POWELL

BY
Cannolly and Hart
HIS ATTORNEYS

Jan. 31, 1956

G. W. POWELL

2,732,666

CENTRIFUGAL BLASTING APPARATUS

Filed Sept. 23, 1952

6 Sheets-Sheet 6

Fig. 10

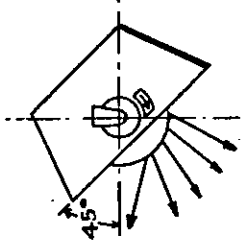

Fig. 9

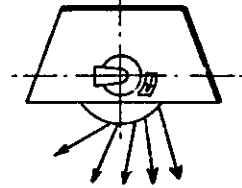

Fig. 8

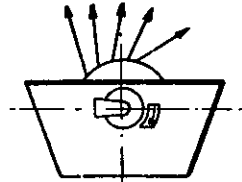

Fig. 7

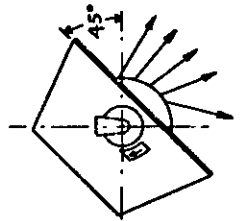

Fig. 6

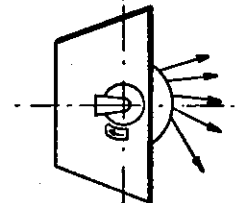

Fig. 15

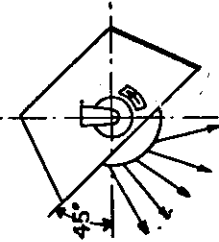

Fig. 14

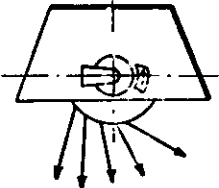

Fig. 13

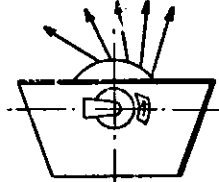

Fig. 12

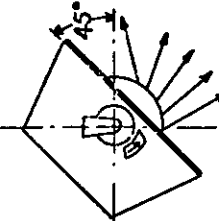
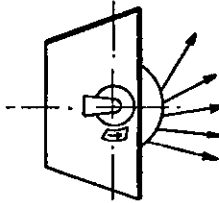

Fig. 11



INVENTOR.
GEORGE W. POWELL

BY
Cannolly and Haly
HIS ATTORNEYS