

[54] METAL SURFACE TREATING APPARATUS FOR INTERNAL SURFACES

[72] Inventors: William J. Koenecke, Glen Rock, N.J.; Joel R. Lazar, New York, N.Y.

[73] Assignee: Metal Improvement Company, Inc.

[22] Filed: Sept. 15, 1970

[21] Appl. No.: 72,391

[52] U.S. Cl. 72/53
 [51] Int. Cl. C21d 7/06
 [58] Field of Search 72/53; 51/9, 319, 320, 321

[56] References Cited

UNITED STATES PATENTS

2,439,032	4/1948	Almen	51/11
3,485,073	12/1969	Burney	72/53
3,531,964	10/1970	Manning	51/319

FOREIGN PATENTS OR APPLICATIONS

13,808 6/1928 Australia72/53

Primary Examiner—Charles W. Lanham
 Assistant Examiner—Gene P. Crosby
 Attorney—Arthur Frederick and Victor D. Behn

[57] ABSTRACT

The metal surface treating apparatus comprises a tubular lance, which is supported for rectilinear movement and connected to receive pressurized fluid and solid particles and discharge the same from one end thereof, and a deflector mounted adjacent to the discharge end of the lance and for rotation about the lance to direct the discharging stream of fluid and particles. The deflector is constructed and arranged to coact with the lance, upon rectilinear movement of the lance relative to the deflector, to automatically alter the direction of the stream of fluid and particles between one extreme position where the stream discharges in a direction substantially normal to the longitudinal axis of the lance and another extreme position in which the stream is directed coincident with the longitudinal axis of the lance.

10 Claims, 5 Drawing Figures

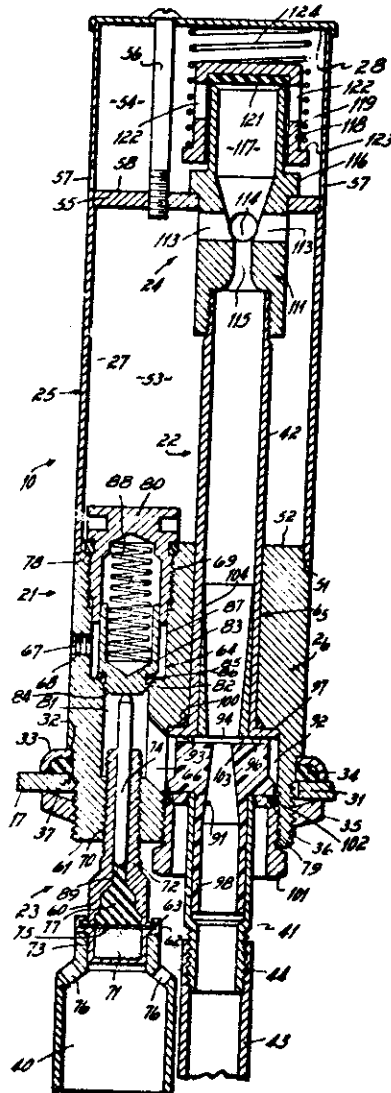

METAL SURFACE TREATING APPARATUS FOR INTERNAL SURFACES

DISCLOSURE OF THE INVENTION

This invention relates to metal surface treating devices, and more particularly, to shot peening or abrading apparatuses of the type having a nozzle from which a high velocity stream of pressurized fluid and entrained solids is discharged to impinge against internal metal surface to be treated.

BACKGROUND OF THE INVENTION

In surface treating apparatuses for peening or abrading internal surfaces, it is conventional to provide a discharge nozzle disposed at the end of an elongated tubular member called a "lance." In such apparatuses, as exemplified in the U.S. Pat. to Almen, No. 2,439,032 and the Australian Pat. No. 13,808/28, the lance or the workpiece is mounted for reciprocable movement and the nozzle is constructed and arranged to direct a high velocity stream of fluid and entrained solids, hereinafter referred to as "shot blast stream," substantially normal to the path of movement of the lance or workpiece so that the internal surface to be treated is subjected to the impacts of the particles in the shot blast stream. Also, it is conventional in some apparatuses to mount the lance for rotation. In presently known devices for treating internal surfaces as disclosed in the U.S. Pat. to Burney, No. 3,485,073, the lance, including the discharge nozzle at the end of the lance, is supported for simultaneous rectilinear and rotative movement relative to the internal surfaces to be treated. None of the aforementioned devices, including the relatively complex and expensive apparatus revealed in the aforesaid U.S. Pat. No. 3,485,073, is capable of treating the internal bottom surfaces of "blind" holes or vessel-like members. Therefore, to treat such internal bottom surfaces, one or more different surface treating apparatuses must be employed. Obviously, this necessity for employing an additional device and fabrication step to treat internal bottom surfaces is undesirable.

Accordingly, it is an object of this invention to provide a surface treating apparatus for treating internal surfaces, which apparatus is relatively simple in construction and inexpensive to fabricate and easy to operate.

Another object of the present invention is to provide a surface treating apparatus for treating internal surfaces, which apparatus is capable of directing a shot blast stream within a semi-spherical plane.

A further object of this invention is to provide a surface treating apparatus which is capable of directing a shot blast stream against both the internal side wall surfaces and the bottom surface or surfaces of a "blind" hole or vessel-like member.

A still further object of the present invention is to provide a surface treating apparatus, having a lance and nozzle means, capable of automatically adjusting to direct a shot blast stream progressively between a direction normal to the longitudinal axis of the lance to a direction coincident with the longitudinal lance axis.

A feature of the surface treating apparatus, according to this invention, is the deflector nozzle assembly which is supported for rotation relative to the lance to direct the shot blast stream through a 360° path and is constructed and arranged to automatically adjust position, upon translatory movement of the lance, to direct the shot blast stream between one extreme position where the stream is emitted in a direction substantially normal to the longitudinal axis of the lance and another extreme position in which the stream is directed coincident with the longitudinal axis of the lance.

Another feature of this invention is the pivotal mounting of the deflector plate of the deflector nozzle assembly and the means for resiliently biasing the deflector plate toward the path of reciprocative movement of the lance to insure continuous contact of the deflector plate against the lance.

SUMMARY OF THE INVENTION

The present invention, therefore, contemplates a novel metal surface treating apparatus for internal surfaces comprising a tubular lance supported for reciprocative movement relative to the internal surfaces to be peened and a deflector nozzle assembly supported for rotation adjacent the discharge end portion of the lance to direct the shot blast stream through a 360° path about the lance.

The deflector nozzle assembly comprises a frame or support to which is pivotally mounted a deflector plate. The assembly is mounted on a support means so that the deflector plate lies in the path of the shot blast stream discharging from the lance to redirect such stream. A resilient biasing means is included in the deflector nozzle assembly to urge the deflector nozzle in a direction toward the lance, and into the path of emissions from the lance. The deflector plate functions, as the deflector nozzle assembly rotates relative to the lance, to deflect the shot blast stream through a 360° path. The deflector plate is so constructed that in one extreme operative position, as it rotates through 360° about the lance, it functions to redirect the shot blast stream emission from the lance in a direction substantially normal, or at right angles, to the longitudinal axis of the lance, and in another extreme operative position, functions to permit discharge of the shot blast stream in a direction coincident with the longitudinal axis of the lance. The deflector plate also coacts with the reciprocative movement of the lance to automatically and progressively adjust the direction of discharge of the shot blast stream between the aforementioned two extreme operative positions. This function of the apparatus thus permits its use to surface treat the internal bottom surfaces as well as the internal side surfaces of "blind" holes and vessel-like members.

BRIEF DESCRIPTION OF THE DRAWINGS

The invention will be more fully understood from the following description when considered in connection with the accompanying drawings in which:

FIG. 1 is a side view in elevation of the surface treating apparatus according to this invention;

FIG. 2 is an enlarged fragmentary view of the apparatus shown in FIG. 1 showing the deflector nozzle assembly according to this invention;

FIG. 3 is a top view of the apparatus shown in FIG. 2;

FIG. 4 is a side elevational view of the deflector nozzle assembly shown in FIG. 2; and

FIG. 5 is a cross-sectional view taken substantially along line 5-5 of FIG. 2.

Now referring to the drawing and, more particularly, to FIG. 1, the reference number 10 generally designates the surface treating apparatus, according to the present invention, which comprises three major subassemblies, a lance assembly 11, a deflector nozzle assembly 12, and a hopper-frame assembly 13.

As best shown in FIG. 1, lance assembly 11 comprises an elongated tubular member or lance 14 secured at one end in a connector 15. The connector 15 is mounted on a plate 16 which is disposed within a guide bracket 17. A double-acting pressurized fluid motor 18 of the hydraulic or pneumatic type is secured to bracket 17 so that the piston rod 19 of fluid motor 18 is in alignment with the longitudinal axis of lance 14. The end portion of the piston rod opposite from piston 20 and projecting from the cylinder 21 of fluid motor 18 extends through an opening in the base portion 17A of bracket 17 and is secured in a hub portion 22 of plate 16. When, upon actuation of suitable control valve means (not shown) pressurized fluid from a suitable source (not shown) enters cylinder 21, through fluid pipe 23, piston 20 and piston rod 19 are caused to move upwardly, as viewed in FIG. 1, with fluid exhausting ahead of the piston, through fluid pipe 24. Upward movement of piston rod 19 forces plate 16, connector 15, and lance 14 to move upwardly. Conversely, when through actuation of suitable controls (not shown) pressurized fluid enters cylinder 21

of the fluid motor 18, via fluid pipe 24, the piston 20 is forced to move downwardly, as viewed in FIG. 1, with the fluid ahead of piston 20 exhausting through fluid pipe 23. Obviously, downward movement of piston rod 19 effects downward translation of plate 16, connector 15, and lance 14.

The lance is supported and guided at its upper end portion for the aforementioned reciprocative movement by a bushing 25, preferably of rubber, which is supported in a cup-shaped end portion 26 of a tubular drive shaft 27. The shaft 27 is connected for rotation to a rotary motor 28 of any suitable type, such as a fluid or electric motor, which may have a hollow rotor through which lance 14 can extend. The motor 28 is mounted on a base 29 which is secured by a plurality of bolts 30 to a top plate portion 17B of bracket 17. The shaft 27 is supported for rotation in a bushing 31 disposed in a tubular support column 32 which is secured to, and forms part of, hopper-frame assembly 13. The upper end portion of drive shaft 27 is provided with a mounting flange 36 to which is secured deflector nozzle assembly 11 for conjoined rotation with shaft 27.

The lance 14 is connected to a suitable source (not shown) of solid particles, or shot, entrained in a pressurized fluid stream through a flexible conduit 37 which is secured, at one end, to connector 15 and at the opposite end to the aforementioned fluid and shot source.

The hopper-frame assembly 13 includes a suitable supporting frame (only part of one beam 38 being shown) for support of the entire apparatus 10 and a hopper 39 (only part of which is shown) for the collection and recovery of shot or other solid particles. The frame may also serve to support other auxiliary devices and components (not shown), such as a shot feed tank, shot classifying device, air blower, and electrical and fluid control elements.

As best shown in FIGS. 2 to 5, deflector nozzle assembly 12 comprises a support 40 and a deflector plate 41 pivotally connected to support 40.

The support 40 comprises a horizontal base portion 42 and a vertically extending bracket portion 43. The base portion 42 is secured by bolts 44 to mounting flange 36 of drive shaft 27 and has a central hole 45 which is dimensioned to receive therethrough lance 14. With base portion 42 connected to mounting flange 36, bracket portion 43 extends in close spaced, parallel relationship to the upper end portion of lance 14. The upper distal portion of bracket portion 43 is provided with horizontal ears or wings 46 just below the plane of the nozzle or discharge end 14A of lance 14. One segment 47A of a pair of hinges 47 is secured to each of the wings 46, the function of the hinges being fully explained hereinafter.

The deflector plate 41 comprises a unitary channel element of high wear resistance material, such as tungsten carbide, and having a compound curvature. As best shown in FIG. 5, deflector plate 41, in cross section, has in one surface thereof an arcuate shaped recess 48, the curvature of which is substantially complementary to the exterior curvature of lance 14 and is dimensioned so that end portion 14A of lance 14 can engage and partly ride within recess 48 upon rectilinear translation of lance 14. Two laterally extending ears or wings 49 are secured in any suitable manner, such as welding, brazing, or the like, to one end of deflector plate 41. The opposite segments 47B of the pair of hinges 47 are connected to wings 49 so that deflector plate 41 is pivotally secured, through hinges 47, to bracket portion 43. The deflector plate 41 is resiliently biased in a direction toward the longitudinal axis of lance 14 by a compound leaf spring assembly 50. The spring assembly consists of two flat, elongated spring elements 51 and 52 each of which is secured at one end to the lower portion of bracket portion 43 by bolts 53. The deflector plate 41 is limited in pivotal movement in a direction to the right, as reviewed in FIG. 2, by stop bars 54 which are secured by welding, or the like, to wings 46 and extend beyond wings 46 to provide a stop against which wings 49 can abut. The stop bars 54 are formed with a slight bend so that, when wings 49 are in engagement with the stop bars 54, deflector plate 41 is positioned in the

path of shot blast stream emissions from the discharge end 14A of lance 14, as shown in full lines in FIG. 2. In this extreme position of deflector plate 41, the deflector plate functions to deflect the shot blast stream in a direction substantially normal to the longitudinal axis of lance 14.

Each of the hinges 47 is preferably, as shown, constructed of plastic strips having a central portion 47C which is integral with hinge segments 47A and 47B and is of reduced dimension in cross section to provide a relatively flexible area and thereby permit pivotal movement of hinge segment 47B relative to hinge segment 47A. This type of hinge can be purchased from Stokes-Trenton, Inc. under the trade name "Polyhinge." This type of hinge is preferred since it has a relatively long operative life as compared with a conventional pin type mechanical hinge which readily becomes jammed with the metal particles and shot particles discharged from lance 14.

In operation of the surface treating apparatus 10 herein described, a pressurized stream containing entrained solid particles is delivered from a suitable source thereof (not shown) to the bore of lance 14, via flexible conduit 37 and connector 15. This shot blast stream discharges from the nozzle or discharge end 14A of lance 14 and into impingement against the arcuate recess 48 of deflector plate 41, which recess deflects the stream so that it is directed in a direction substantially normal to the longitudinal axis of lance 14. Simultaneously, with the discharge of a shot blast stream, as above described, motor 28 rotates drive shaft 27 which, in turn, rotates mounting flange 36 and deflector nozzle assembly 12 secured to the mounting flange. As the deflector plate 41 is carried in a circular path about lance 14, the deflector plate directs the shot blast stream in a 360° circular discharge pattern.

When it is desired to reposition the point of impaction of the shot blast stream, the lance 14 is caused to rectilinearly translate by introducing pressurized fluid into double-acting-piston cylinder 18, via pipe 23. The upward movement of piston 20 forces plate 16 upwardly and, in turn, connector 15. The upward movement of connector 15 moves lance 14 along its longitudinal axis. As the lance 14 is rectilinearly moved relative to deflector nozzle assembly 12, the discharge end 14A of lance 14 abuts recess 48 and, in so doing, cams deflector plate 41 from the full line position shown in FIG. 2 to the left as viewed in FIG. 2 and toward the broken line position also shown in that Fig. This camming action causes pivotal movement of deflector plate 41, at hinges 47, against the counter force of spring elements 51 and 52. Pivotal movement of deflector plate 41 automatically alters the point of impaction of the shot blast stream on the walls of a "blind" hole 60 (the "blind" hole being shown in FIG. 1). As lance 14 is rectilinearly indexed relative to deflector nozzle assembly 12, the deflector plate 41 is cammed until the deflector plate 41 is moved out of the path of discharge of the shot blast stream emitted from lance 14 so that the shot blast stream is coincident with the longitudinal axis of the lance. This swing of deflector plate 41 simultaneously with its rotation about lance 14 effects a progressive discharge of a shot blast stream through a semi-spherical plane, and thereby provides for impaction, not only against the side walls of hole 60, but also along the bottom surface 61 of the hole (see FIG. 1).

After the internal surfaces are treated to the degree desired, the lance is retracted by actuation of suitable controls (not shown) to cause pressurized fluid to enter cylinder 21, via pipe 24, and thus force piston 20 downwardly. This piston movement moves lance 14 downwardly, via piston rod 19, plate 16, and connector 15. As lance 14 retracts, spring elements 51 and 52 biases deflector plate 41 to pivot about the hinges 47 and against lance discharge end 14A so that the deflector plate eventually assumes the initial extreme position shown in full lines in FIG. 2.

It is now believed readily apparent that the present invention provides a surface treating apparatus which is relatively simple in construction and easily operated to effect the sur-

5

6

face treatment of the internal surfaces of "blind" holes in workpieces and vessel-like members or workpieces. This surface treating apparatus functions also to automatically provide for the alteration of the direction of the shot blast stream to effect impact on the internal side surfaces as well as on the internal bottom surfaces of a workpiece. It is an apparatus which has a relatively long operative life since the deflector plate is of a material highly resistant to abrasion and the hinges are of plastic material which is not subject to binding upon contamination by dust particles and/or shot.

Although but one embodiment of the invention has been illustrated and described in detail, it is to be expressly understood that the invention is not limited thereto. Various changes can be made in the arrangement of parts without departing from the spirit and scope of the invention as the same will now be understood by those skilled in the art.

What is claimed is:

1. In a surface treating apparatus having an elongated tubular lance supported for reciprocative movement along its longitudinal axis and connected to receive pressurized fluid and solid particles and discharge the same in a stream from one end thereof, the combination comprising:

- a. a deflector means supported adjacent the discharge end of the lance and in the path of the stream discharging from the lance to redirect such stream in a selected direction;
- b. the deflector means being adjustably supported and coacting with the lance to alter the direction of said stream in response to rectilinear movement of the lance between one extreme operative position where the stream is directed substantially normal to the longitudinal axis of the lance and another extreme operative position where the deflector means permits the stream to issue in a direction coincident with the longitudinal axis of the lance.

2. The combination of claim 1 wherein said deflector means is rotatively supported and rotation power means is provided to rotate the deflector means about the lance.

3. The combination of claim 2 wherein said rotation power means includes a tubular drive shaft through which the lance coaxially extends and a motor means for rotating the drive shaft.

4. The combination of claim 1 wherein the deflector means includes a pivotally mounted deflector plate.

5. The combination of claim 4 wherein said deflector plate is a channel-like member.

6. The combination of claim 4 wherein said deflector plate has a compound curvature and an arcuate recess extending along the length of the plate into which the discharging stream impacts and is redirected.

7. The combination of claim 1 wherein the deflector means includes a pivotally mounted deflector plate resiliently biased toward the path of the stream discharging from the lance.

8. The combination of claim 1 wherein the deflector means includes a pivotally mounted deflector plate and a spring biasing means for continuously urging the deflector plate in a direction toward the path of the stream discharging from the lance.

9. In a surface treating apparatus having an elongated cylindrical lance supported for reciprocative movement along its longitudinal axis and connected to receive pressurized fluid and solid particles and discharge the same in a stream from one end thereof, the combination comprising:

- a. a deflector means rotatively supported adjacent the discharge end of the lance and in the path of the stream discharging from the lance to redirect such stream in a selected direction;
- b. the deflector means being angularly adjustable in response to rectilinear movement of the lance to direct the stream progressively throughout a semi-spherical plane about the discharge end of the lance.

10. The apparatus of claim 9 wherein said deflector means includes a support, a deflecting plate pivotally mounted on said support, and a biasing means connected to the support and coacting with the deflecting plate to urge the latter in a direction toward the longitudinal axis of the lance.

* * * * *

40

45

50

55

60

65

70

75

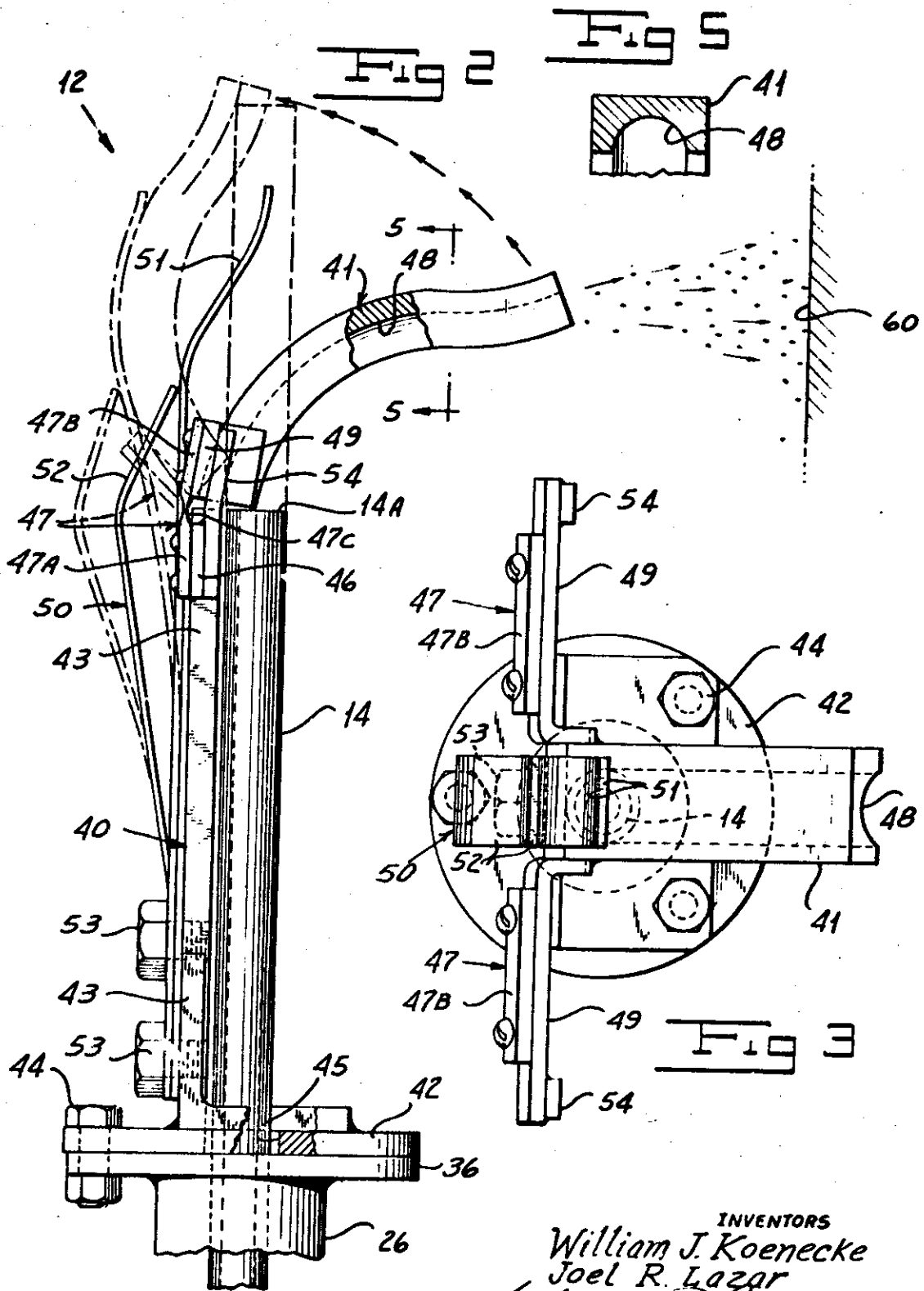

INVENTORS
William J. Koenecke
Joel R. Lazar
Arthur Federick
ATTORNEY