

Residual Stresses in Girth Butt Welded Pipes and Treatments to Modify These

Tasuku Shimizu, Kunio Enomoto, Shinji Sakata

Mechanical Engineering Research Laboratory, Hitachi Ltd,
502, Kandatsu-machi, Tsuchiura-shi, Ibaraki, Japan

&

Wataru Sagawa

Hitachi Works, Hitachi Ltd,
3-1-1, Saiwai-cho, Hitachi-shi, Ibaraki, Japan

(Received: 19 September, 1983)

ABSTRACT

A number of Type 304 stainless steel pipes are used in the primary cooling systems of nuclear plants. Intergranular stress corrosion cracks (IGSCC) were found at some welded joints in these piping systems due to very high tensile residual stress, sensitization of the material due to welding, and corrosive environment, all occurring simultaneously. Investigations have shown that at least one of the above factors must be eliminated to prevent IGSCC.

This report describes experimental results on the temperature variations during pipe welding by conventional techniques and by the heat sink welding (HSW) technique. The mechanism of residual stress generation due to welding is also discussed. The pipe used in these experiments was 4B Sch80 Type 304 stainless steel. It was found that the temperature distribution through the thickness of the pipes was almost uniform for the conventional welding technique, but had a very sharp gradient for HSW. In the pipe axial direction, the temperatures varied sharply for both welding techniques. This implies that the sensitization of metal due to HSW is lighter than that of conventional welding and that the residual stress on the inside surface of the heat sink welded pipe is compressive.

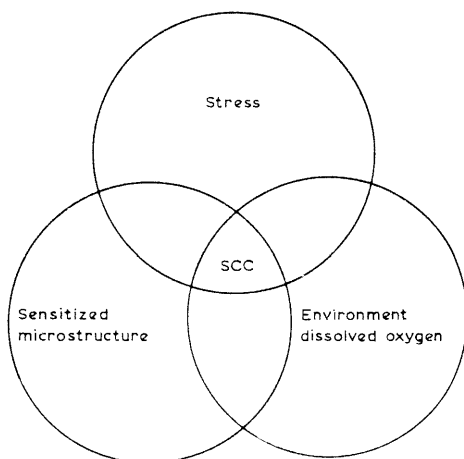

Fig. 1. Parameters influencing IGSCC in type 304 stainless steel.

In this report residual stresses due to conventional and HSW welding are described. Also, the generating mechanism of welding residual stresses is discussed briefly. Then, the IHSI method is discussed from the viewpoint of effectiveness in suppressing fatigue crack growth. Relaxation of the residual stresses and application of IHSI to several types of piping components are also discussed.

WELD RESIDUAL STRESSES

Test specimens

A Type 304 stainless steel pipe (Heat TH8809-B0784) specimen of 4B Sch80 ($D_o = 114.3$ mm, $t = 8.6$ mm, $l = 300$ mm) is shown in Fig. 2. The location of thermocouples was concentrated in the vicinity of the welded portion as shown in Fig. 2(b). Two thermocouples were inserted into the middle of the pipe thickness and three thermocouples were attached 0.5 mm beneath the inside surface of pipes. The thermocouples provided temperature distribution through the thickness as well as along the outside and inside surfaces of pipes during welding.

Welding conditions

Pipes were welded in 1G (flat) position while rotating. The first three passes were welded by TIG welding. In the second and third passes,

The induction heating stress improvement (IHSI) method has been investigated analytically and experimentally. In the IHSI method, a pipe is heated with an induction coil while cold water is pumped through it. This causes a temperature gradient throughout the pipe wall which generates high thermal stresses. This, in turn, generates compressive stresses on the inner surface of the pipe. This method is designed to eliminate tensile residual stresses near the weld heat affected zone on the inner surface.

Temperature analysis and subsequent thermoelastic-plastic analysis show that tensile weld residual stresses at a joint were changed into compressive stresses on the inner surface of a pipe. It was confirmed experimentally that these stresses suppressed fatigue crack propagation in the heat affected zone (HAZ) of a welded pipe. Therefore, the IHSI method is effective not only in preventing crack initiation but also in suppressing crack propagation.

As for the relaxation of residual stresses, no significant relaxation was measured when external loads were applied at as much as 80% of the yield strength in the experiments.

INTRODUCTION

A number of Type 304 stainless steel pipes are used in the primary cooling systems of nuclear plants. Intergranular stress corrosion cracks (IGSCC) were found to occur at some welded joints in these piping systems jointly due to very high tensile residual stresses, sensitization of the material due to welding, and a corrosive environment, as shown schematically in Fig. 1.

Investigations^{1,2} have shown that at least one of the above factors must be eliminated to prevent IGSCC. In terms of sensitization of the materials, other materials should be used such as Type 316 stainless steel nuclear grade which has very high resistance against IGSCC. Another method to prevent IGSCC is to apply a different water chemistry to the coolant inside the pipes. These methods have already been effectively applied to several actual plants.

Concerning the last of the three factors in Fig. 1, i.e. very high tensile residual stresses, a few methods have been developed to eliminate the high tensile stresses and to generate compressive stresses instead. Such methods are Heat Sink Welding (HSW), or Last Pass Heat Sink Welding (LPHSW) and Induction Heating Stress Improvement (IHSI).

welding are shown in Figs 3 and 4 for conventional and HSW welding, respectively. These curves were plotted from several recorders; therefore, the abscissa does not represent the actual times for these curves. The times at which the temperature increased in each curve were matched in the figures.

For conventional welding, temperatures go up very quickly and fall

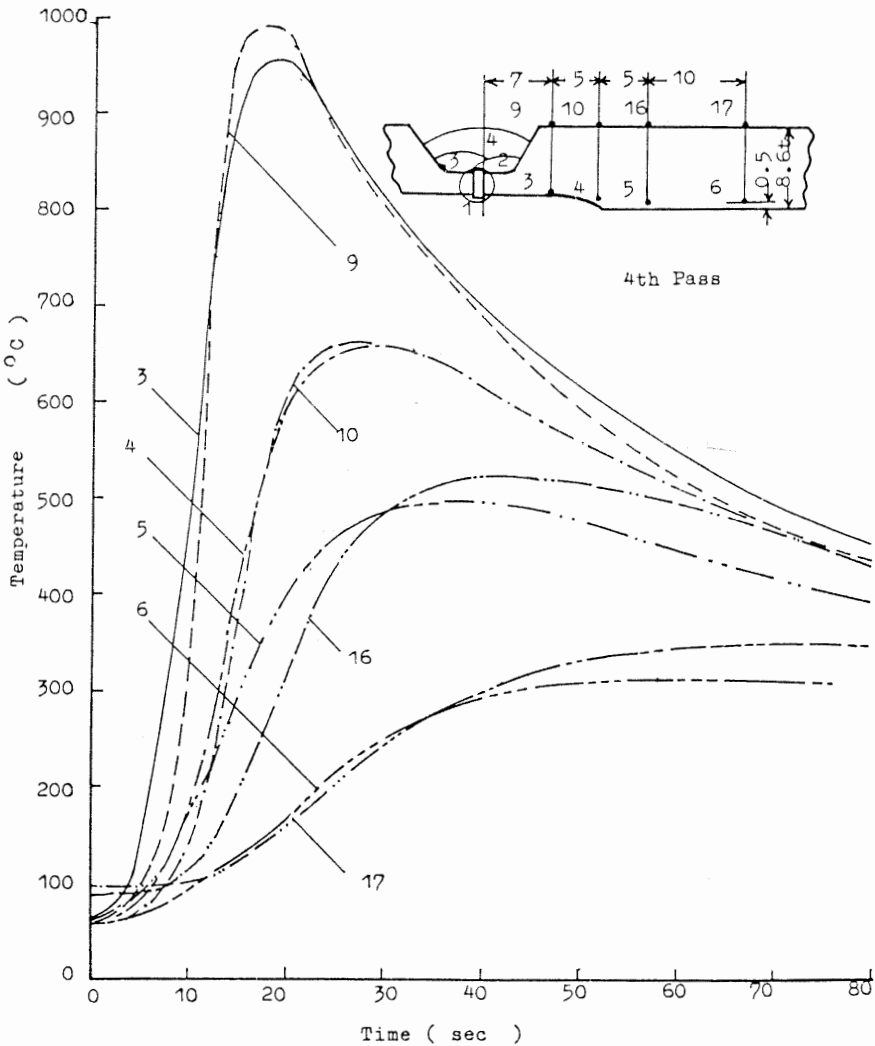

Fig. 3. Temperature profiles along the inside and outside surface of 4B Sch80 pipe (conventional welding).

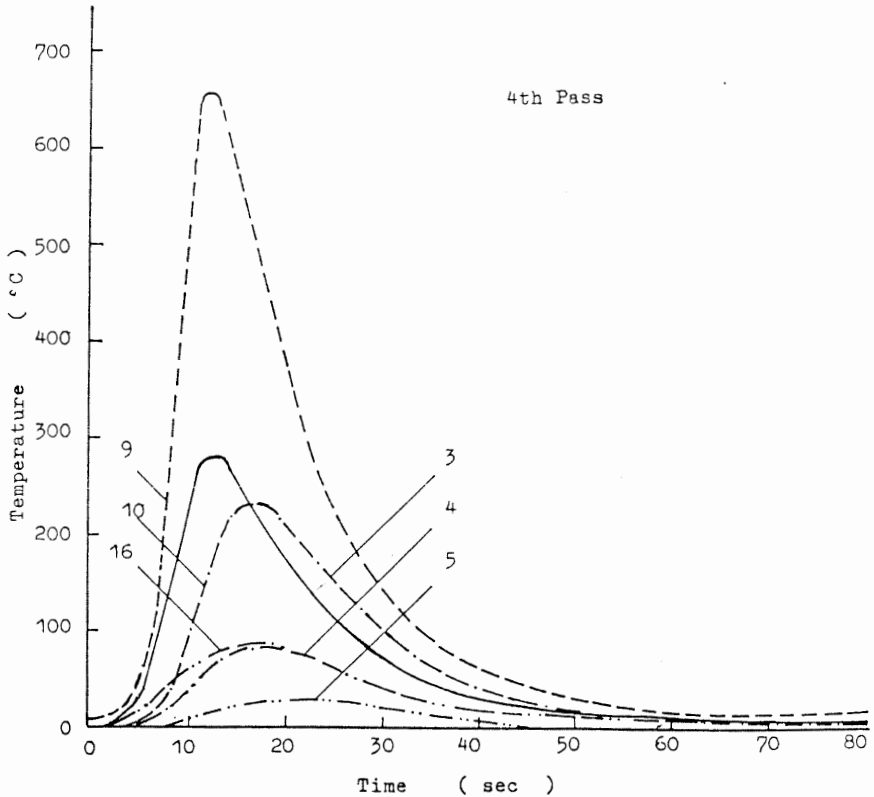
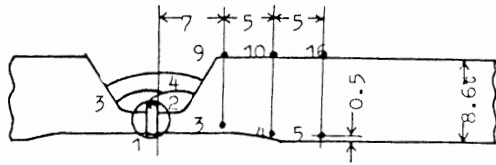

Fig. 4. Temperature profiles along the inside and outside surface of 4B Sch80 pipe (HSW).

slowly. Also, there is little temperature difference between the outside and inside surfaces of the pipe. For example, the temperature at point 9 varied with time in the same way as that at point 3, as shown in Fig. 3. On the other hand, temperatures rise and fall quickly, and the temperature differences between the outside and inside surfaces of the pipe are very large for HSW as shown in Fig. 4.

Weld residual stresses

After completing the pipe butt welding, residual stresses were measured by the stress relief method with electrical resistance wire strain gauges. To obtain stresses from measured strains, values of 1.98×10^4 kgf/mm² and 0.3 for Young's modulus *E* and Poisson's ratio, respectively, were used. Residual stress distributions on the outside and inside surfaces along the pipe axis are shown on Figs 5 and 6. Tensile residual stresses were measured at the heat affected zone (HAZ) on the inside surface, where IGSCC would occur under corrosive conditions, such as high

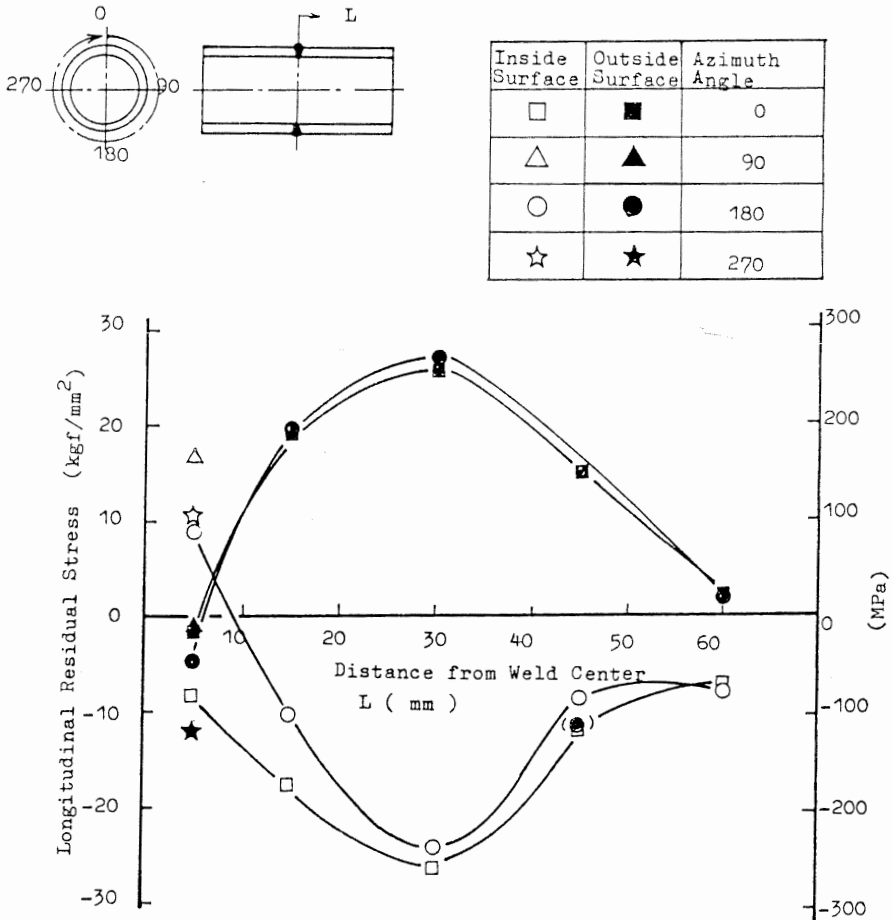

Fig. 5. Longitudinal residual stress distribution (conventional welding).

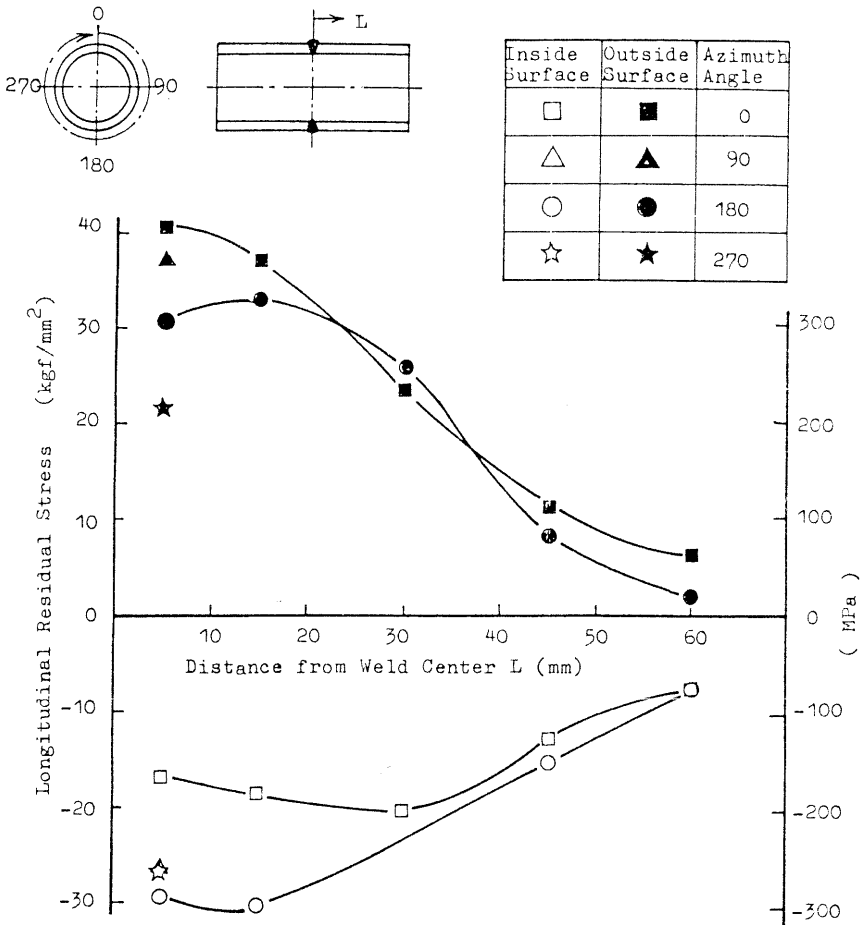

Fig. 6. Longitudinal residual stress distribution (HSW).

temperature pure water with dissolved oxygen, as shown in Fig. 5. On the contrary, there were no tensile residual stresses on the inside surface of the HSW welded pipe as shown in Fig. 6. Figures 5 and 6 show only the longitudinal residual stresses, but this distinction between conventionally and HSW welded pipes, respectively, also holds for the circumferential residual stresses.

The characteristics of residual stress distributions for a conventionally welded pipe and a HSW welded pipe were determined from temperature distributions for each pipe during welding as shown in Figs 3 and 4. For the case of no temperature gradient through the thickness of a pipe, no

thermal stress occurs at this point. Radial shrinkage of the pipe after welding only causes residual stresses which are tensile on the inside surface and compressive on the outside surface. This is the case for conventional welding. When there is a large temperature gradient across the pipe wall thickness, high thermal stresses over the yield strength of the pipe material occur during welding. Those stresses are superposed on the residual stresses caused by the radial shrinkage. In HSW welded pipes the former residual stresses are much higher than the latter. Therefore, compressive residual stresses were obtained on the inside surface of the pipe as shown in Fig. 6.

INDUCTION HEATING STRESS IMPROVEMENT

As described in the previous section, tensile residual stresses are generated at the HAZ on the inside surface of a pipe by conventional welding. High tensile residual stress is one of the three factors that may cause IGSCC in stainless steel piping of BWR plants. Therefore, the elimination of the tensile residual stresses is an effective countermeasure for IGSCC. From this standpoint, the induction heating stress improvement (IHSI) method was invented by Hitachi Ltd, and applied to actual plants.

The basic principle and effectiveness of IHSI are set out in the following paragraphs and various actual applications are also described.

Experimental verification

Compressive residual stresses were generated by HSW, where there was a large temperature gradient during welding. Basically the IHSI method is based on the same theory as the HSW method.

Essential components of equipment for IHSI treatments, as well as illustrations of the IHSI principle, are shown in Fig. 7. The IHSI process involves the simultaneous heating and cooling of a pipe from the outside and inside, respectively. Heating to a temperature of approximately 550 °C from the outside of the pipe is accomplished by using an induction heating coil that was specially designed to fit the contour of the welded part of a pipe. Cooling from the inside of the pipe is achieved by flowing water. This prevents the temperature of the inside of the pipe from rising. This procedure is schematically shown in Fig. 7(a) and the IHSI treatment specifications are summarized in Table 1. The above process

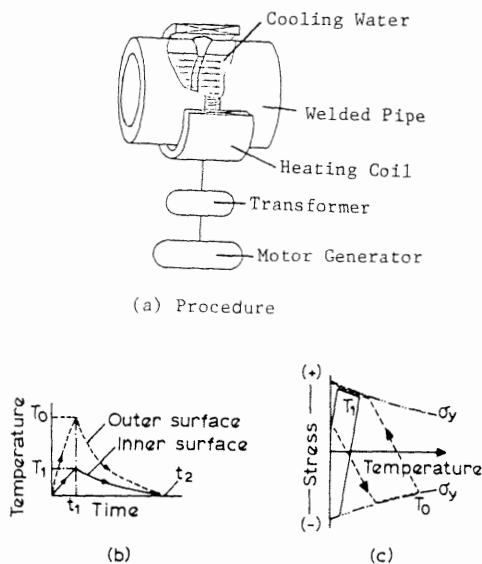

Fig. 7. Induction Heating Stress Improvement (IHSI).

produces a temperature gradient through the pipe wall as shown in Fig. 7(b). The temperature gradient plastically deforms the inner pipe surface by tension and the outer pipe surface by compression as indicated in Fig. 7(c). When the induction heating is turned off, the thermal contraction of the outer portion of the pipe wall forces the inner portion of the wall into a state of compressive residual stress as shown in Fig. 7(c).

To prove the IHSI principle experimentally, Type 304 stainless steel pipes (12B Sch100) were used and IHSI treatment was carried out on these pipes. Temperature variations were measured during treatment and the results are plotted in Fig. 8. Plots of temperature distributions on the

TABLE 1
IHSI Treatment Specifications

<i>Item</i>	<i>Specification</i>
Coil width	≥ 250 mm
Water flow rate	≥ 0.43 m/s
Current frequency	3 kHz
Electric input	≥ 300 kW
Heating time	≥ 60 s
Maximum temperature	≤ 500 °C

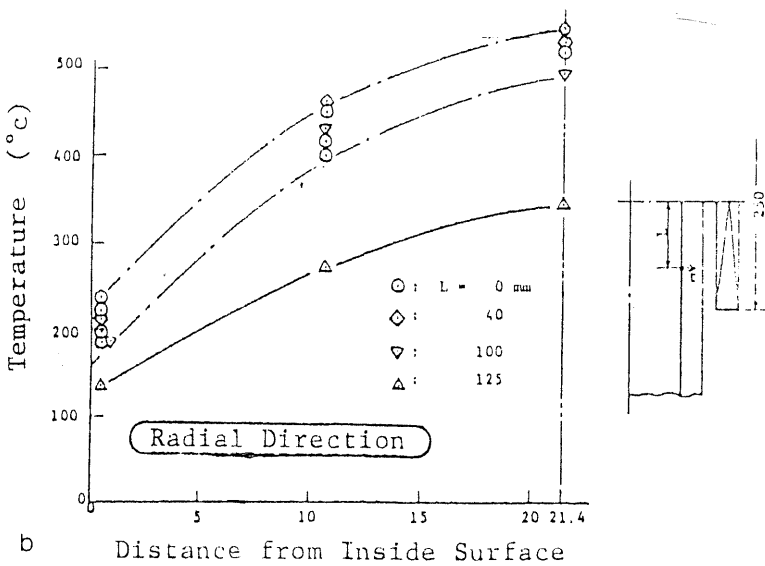
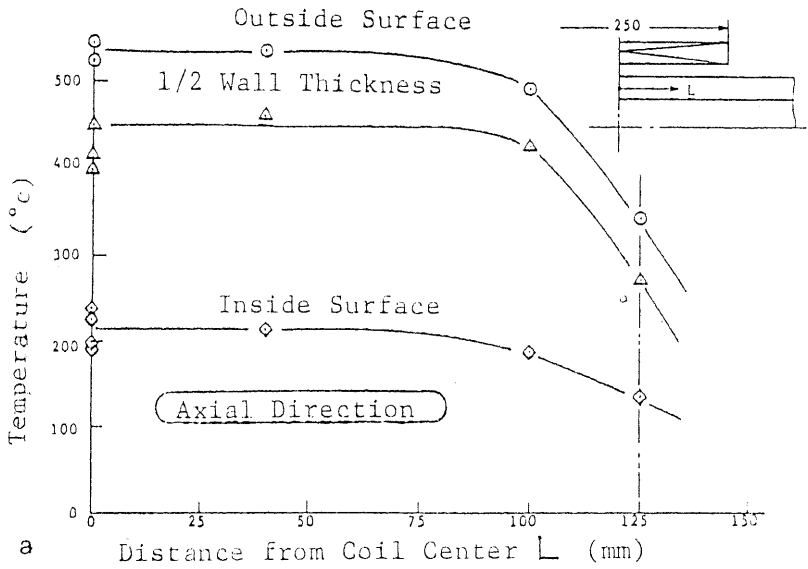

Fig. 8. Temperature distribution of IHSI'd Pipe HF-1.

outside and inside surfaces, as well as at the middle of the pipe wall thickness in the direction of the pipe axis, are shown in Fig. 8(a). Temperature gradients in the pipe wall thickness at several cross-sections at various distances from the weld line are shown in Fig. 8(b). It was found that the temperature gradients shown in Fig. 8(b) are large enough to cause compressive stresses on the inner portion of a pipe. This confirms results obtained by theoretical analysis.

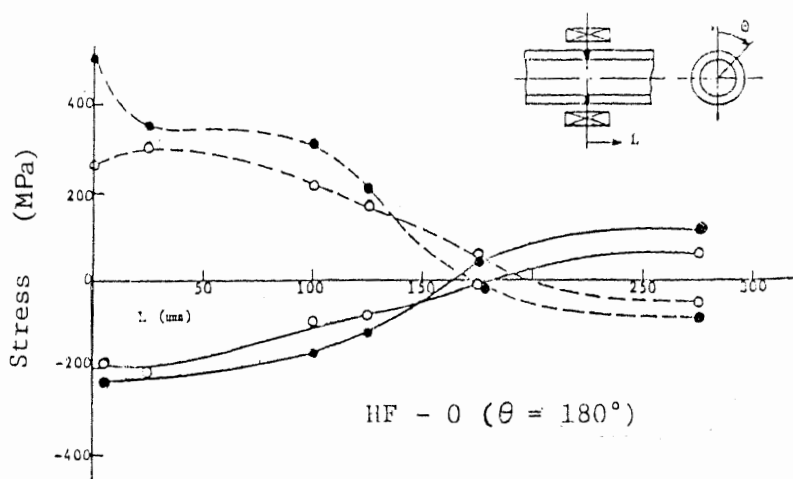
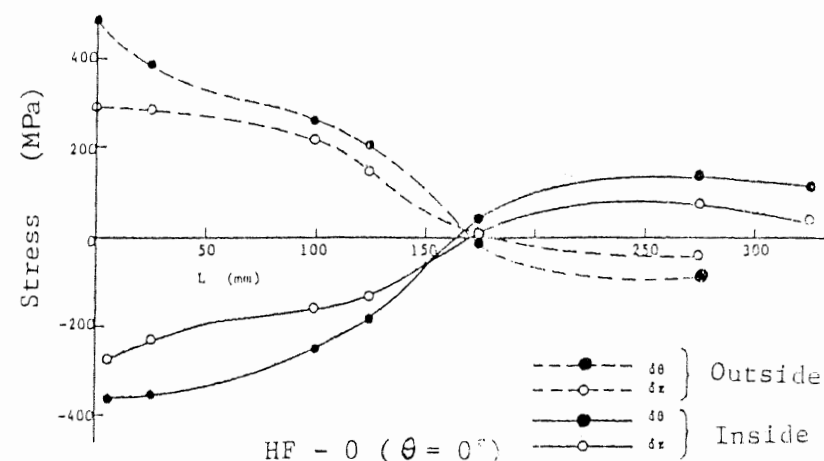

Fig. 9. Residual stress distributions along pipe axis.

After IHSI treatment, residual stresses were measured by cutting the pipe into small pieces. Electrical resistance wire strain gauges were attached to each piece before cutting. The result shows that residual stresses are compressive in the HAZ on the inside surface of the pipe as plotted in Fig. 9. Also, the IHSI principle, as described above, was verified.

Effects on fatigue crack propagation

It is well known that the presence of compressive residual stresses suppresses the occurrence of IGSCC under a high temperature, pure water condition as stated in the first section of this paper. It is also important to show the effectiveness of IHSI in restraining the growth of cracks that hypothetically exist on the inside of pipes.

Fatigue tests for this purpose were carried out by the procedure shown in Fig. 10. Three pipes, i.e. P-, PI- and WI-pipe, were used. The P-pipe was a piece of original Type 304 stainless steel pipe without any heat treatments. The PI-pipe was a piece of the pipe with IHSI treatment at the center portion of it. WI-pipe was fabricated by conventional butt welding

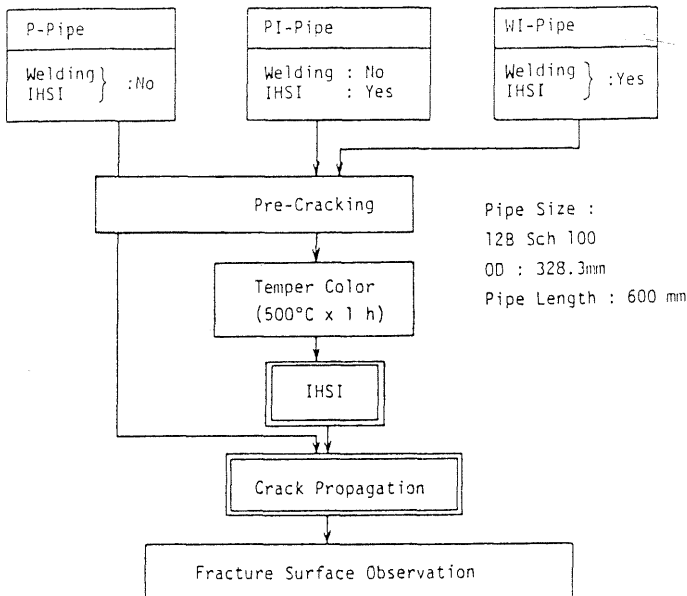

Fig. 10. Experimental procedure.

followed by IHSI treatment after pre-cracking. The three pipes were subjected to loading on the outside of the pipes. Those pipes are listed in Table 2. Crack lengths on the surface were measured by the replica technique. In order to obtain the crack growth rate in the thickness direction, the beach marking technique was applied.

After the final fatigue test, the fracture surfaces were examined to see if there was any crack growth due to static thermal stress during IHSI treatment. The fractographs from PI- and WI-pipe showed that no crack growth was found during the time between pre- and post-IHSI treatment.

TABLE 2
Test Pipes

<i>Pipe</i>	<i>Butt welding</i>	<i>Pre-cracking</i>	<i>IHSI</i>
P	None	None	None
PI	None	Yes	Yes
WI	Yes	Yes	Yes

The crack growth rates obtained from fatigue tests in terms of the stress intensity factor range, K , are shown in Fig. 11. Solid marks were obtained from P-pipe and these agreed with the curve, which gives the standard crack growth rate of Type 304 stainless steel. Hence, the experimental method and data arrangement used were verified. Test results for PI- and WI-pipe gave a much slower crack growth rate than that of P-pipe. When the residual stress of 20 kgf/mm² due to IHSI treatment is assumed as a mean stress, recalculation of the crack growth rate shown in Fig. 11 gives the new crack growth rate for the PI- and WI-pipe. This agrees with the dotted curve for Type 304 stainless steel.

It can be said from the above figures that IHSI is applicable to pipes with relatively small cracks and that it will suppress fatigue crack propagation.

Residual stress relaxation

It has been postulated that residual stresses generated by IHSI treatment may relax after a hydrostatic pressure test and subsequent operation of a plant. It is worth confirming the effective duration of IHSI in actual plants.

then subjected to a cyclical bending load. Applied stress levels for weld lines are shown in Fig. 12. They are from $0.6^{0.2}$ to $1.2^{0.2}$, where the subscript stands for the yield strength at 0.2% strain in the stress-strain curve of Type 304 stainless steel.

The residual stress variation in terms of the number of loading cycles indicates that relaxation occurs during the first 10 loading cycles and that

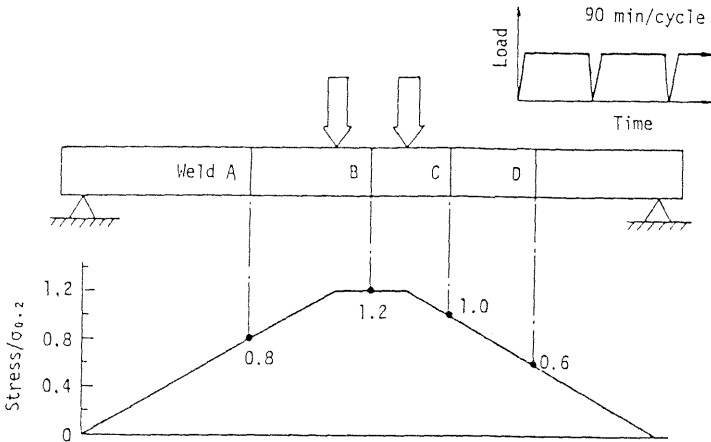
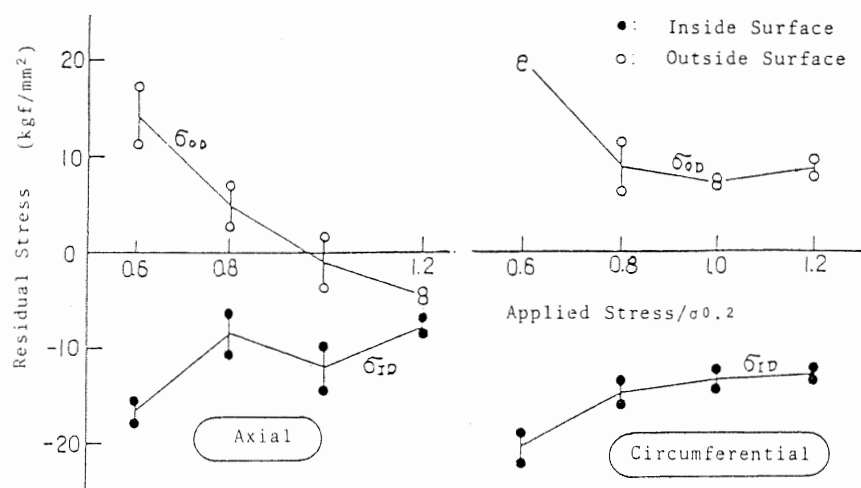

Fig. 12. Relaxation test apparatus.

little relaxation occurs after the tenth cycle. The relaxation test was completed at up to 100 loading cycles. After that, no more relaxation can be expected. Then the test pipe was subjected to detailed strain measurement. Electrical resistance wire strain gauges, of which the gauge length is 2 mm, were attached to the outer surface of the pipe and then the pipe was cut into four short pipes with a weld line at the center of them. The additional strain gauges were then attached to the inner surface of the pipes. These short pipes were again cut into very small pieces which had only one strain gauge on each of them. The measured residual stresses of the pipe after the relaxation test are shown in Fig. 13. One can see that both axial and circumferential residual stresses are in tension on the outer surface and in compression on the inner surface near weld lines A and D where the applied stresses were as low as $0.8^{0.2}$ and $0.6^{0.2}$ respectively. On the other hand the axial residual stresses near weld lines B and C, where the applied stresses were as high as $1.2^{0.2}$ and $1.0^{0.2}$ respectively, were small.

The important thing in Fig. 13 is that the residual stresses on the inner



(a) Tension Side

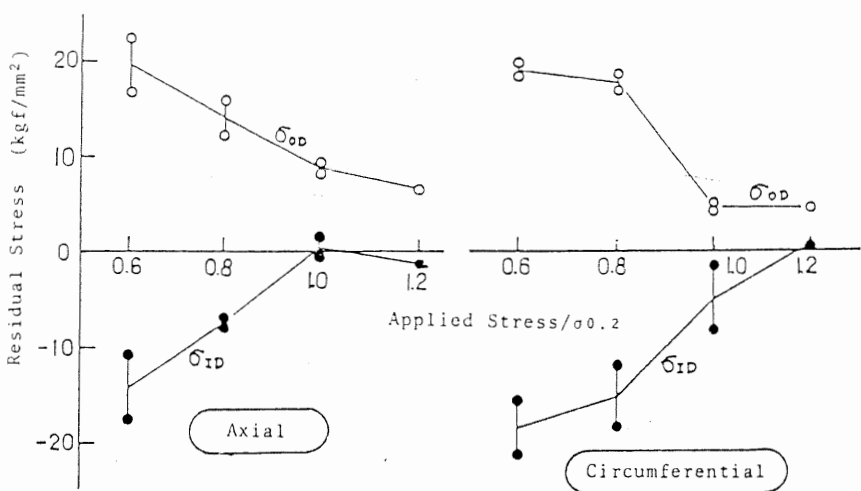

(b) Compression Side

Fig. 13. Effect of applied stress on residual stress at HAZ after relaxation test.

surface of the pipe are always in compression, even if tensile stresses caused by very high external loading exist on the outer surface.

Concerning residual stresses generated by IHSI treatment in pipes at actual plants, thermoelastic-plastic analysis was performed based on the material data obtained in previous experiments. A 24B Sch80 pipe was used for calculation in a primary loop for recirculation (PLR) of a BWR

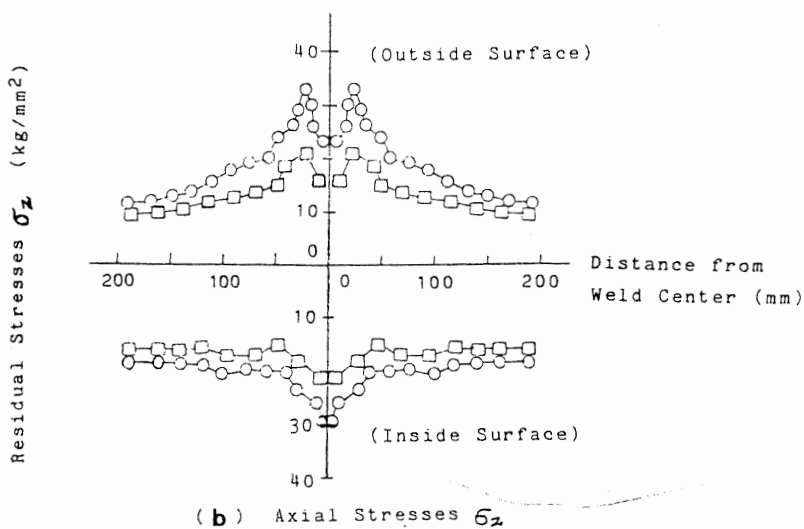
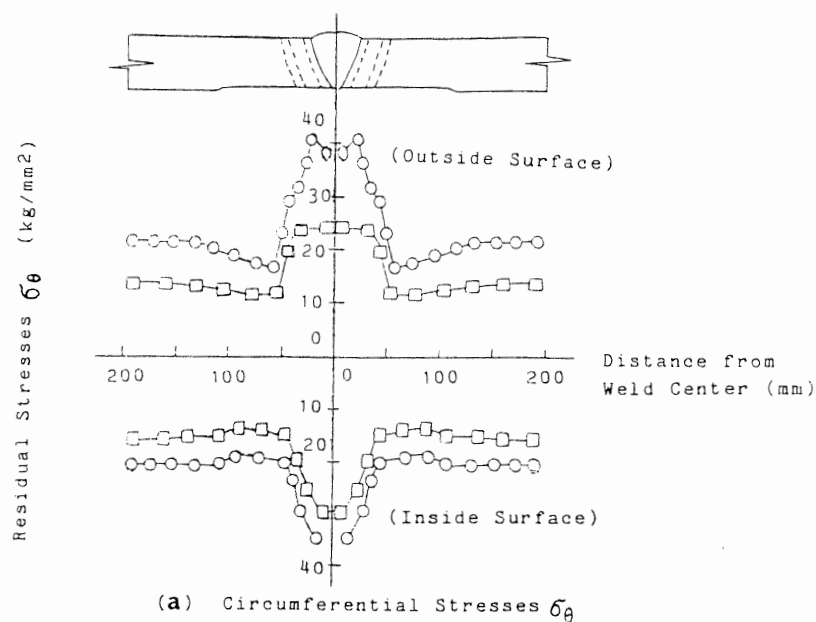

Fig. 14. Stress relaxation behavior of IHSI treated pipe for simulated plant operating conditions.

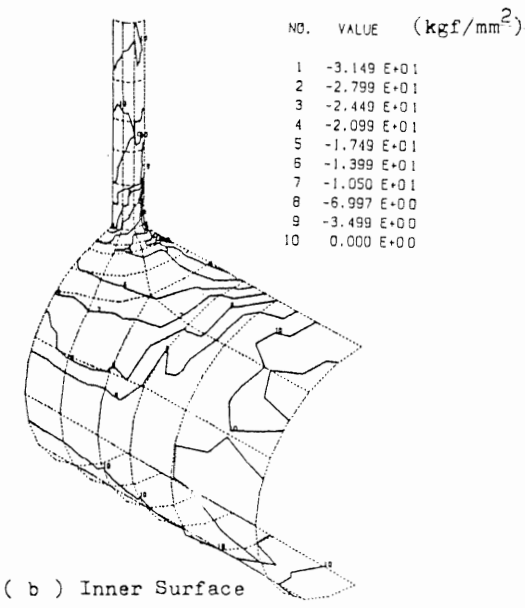
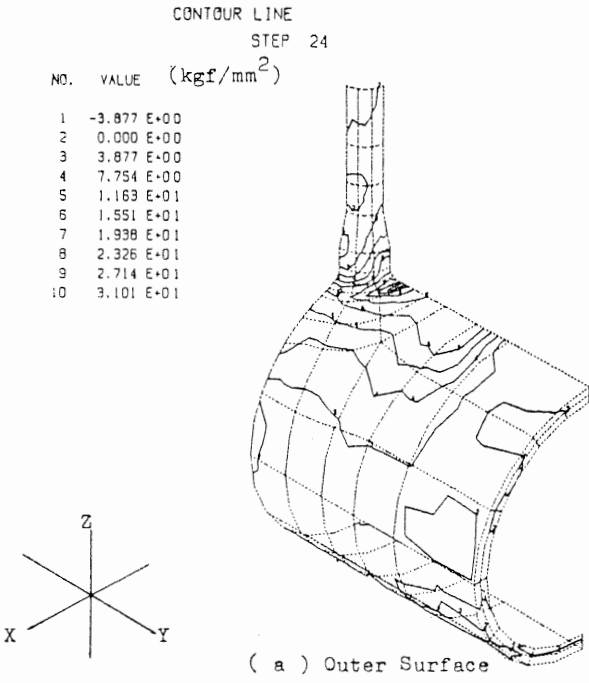

Fig. 15. Residual stress contour for IHSI.

plant. A weld portion of the pipe was IHSI-treated during the calculation and then it was subjected to various thermal transients defined as design conditions for PLR piping, including long-term full power operation. Creep effect must be taken into account in the calculation as well as elastic-plastic analysis for obtaining stress relaxation during BWR operation. The analysis results indicate a reduction factor of about 50 percent maximum, shown in Fig. 14. However, that is still in the compressive region after 40 years of operation.

Application to other piping components

So far the IHSI method has been verified for straight-to-straight butt welded pipe of the same diameter. However, in an actual plant there are various piping components such as reducers, T-junctions, cross joints, elbows and so on. It is necessary to develop IHSI methods for the above components which have irregularly curved weld lines.

Basically, there are no differences between the IHSI methods for various joints. However, what has to be decided is the induction heating coil configurations that will fit the contours of the welded parts of the junctions. For this purpose, theoretical analyses are very effective, and a number of heat transfer calculations and subsequent thermo-elastic-plastic analyses were carried out in order to develop an IHSI method for various piping components. An example of theoretical analysis for a T-joint is shown in Fig. 15. It was found that an appropriate induction coil provides compressive residual stresses on the inside surface along the weld line.

Theoretical calculation results showed very good agreement with experimental results for several cases. However, there are still some uncertainties concerning material constants and residual stresses which may be caused during the manufacturing process of components. Therefore, the analytical results should be confirmed experimentally by using the final model in the analysis at the time when a new IHSI method is applied to actual plants.

CONCLUSIONS

The conclusions of the study are as follows.

1. Temperature distribution patterns for conventional and heat sink welding were very different from each other.

2. Residual stresses in the heat affected zone were tensile on the inside surface of a conventionally welded pipe, but compressive for a heat sink welded pipe.
3. Crack growth rate in an IHSI treated pipe is significantly reduced in comparison with the original pipe.
4. Residual stresses generated by IHSI will relax slightly during operation, but they will remain compressive even after 40 years of plant operation.

REFERENCES

1. Klepfer, H. H., *Investigation of Cause of Cracking in Austenitic Stainless Steel Piping*, General Electric Company Report, No. NEDO-21000, 1975.
2. Danko, J. C., Stahlkopf, K. E. & Rossin, A. D., An overview of boiling water reactor pipe cracking, *Int. J. Pres. Ves. & Piping*, **9** (1981), 401-19.