

United States Patent [19]

[11] **Patent Number:** 4,619,128

Harman et al.

[45] **Date of Patent:** Oct. 28, 1986

[54] **SPINDLE FOR ROTOPEENING APPARATUS**

[75] Inventors: Douglas G. Harman, Pensacola Beach, Fla.; Richard A. Green, Farmington Hills, Mich.; Bruce W. Bevilacqua, Penn Township, Westmoreland County, Pa.

[73] Assignee: Westinghouse Electric Corp., Pittsburgh, Pa.

[21] Appl. No.: 731,250

[22] Filed: May 7, 1985

[51] Int. Cl.⁴ B24C 3/16; C21D 7/06

[52] U.S. Cl. 72/53

[58] Field of Search 72/53, 110, 199, 234, 72/362, 365; 52/241 B

[56] **References Cited**

U.S. PATENT DOCUMENTS

- 3,485,073 12/1969 Burney .
- 3,531,964 10/1970 Manning, Jr. et al. .
- 3,648,498 3/1972 Voss et al. .
- 3,654,786 4/1972 Koenecke et al. .
- 3,834,200 9/1974 Winter .
- 3,857,750 12/1974 Winter et al. .
- 3,886,774 6/1975 Stromstedt et al. .
- 4,034,585 7/1977 Straub .
- 4,354,371 10/1982 Johnson .
- 4,481,802 11/1984 Harman et al. .

FOREIGN PATENT DOCUMENTS

- 2551996 8/1983 France .

OTHER PUBLICATIONS

"Longer Life for Metal Parts by Shot Peening," R. R. Murray, *Machine Design*, Mar. 22, 1984, pp. 57-61.
U.S. Application Serial No. 613,674, Filed May 24, 1984 for "Device for Shot-Peening Inside Surface of U-

Bend Region of Heat Exchanger Tubing", by Douglas Harman et al.

Technical Brochure Entitled "3M Brand Roto Peen Flap Assemblies Type TC 330", Building Service and Cleaning Products Division of 3M Corp., Cleveland, Ohio.

Primary Examiner—Leon Gilden
Attorney, Agent, or Firm—L. A. DePaul

[57] **ABSTRACT**

A rigid peening spindle for rotopeening the inside wall of a tube is disclosed herein. Generally, the peening spindle comprises a rotatable housing insertable within a tube, a mandrel disposed within the housing and having a plurality of peening flappers connected thereto, and a pair of bearings for rotatably mounting the mandrel within the housing in an off-center orientation relative to the longitudinal axis of the housing so that the peening flappers rotate and orbit within the tube when the mandrel and housing are simultaneously rotated. The housing includes a cage formed from an open section and a ligament, and the mandrel is rotatably mounted within the housing so that the peening flappers may engage the inside wall of the tube through the open section of the cage. Finally, each of the bearings which rotatably mount the mandrel in an off-center manner preferably have an outer diameter slightly larger than the outer diameter of the housing so that they may engage the inside wall of the tube in a running engagement within fairly tight tolerances, and thereby control the stand-off distance between the peening flappers and the inside wall of the tube. The bearings are preferably made from a self-lubricating plastic material. The invention is particularly useful in rotopeening the interior walls of the heat exchange tubes of a nuclear steam generator in order to prevent stress corrosion cracking in the tubes.

28 Claims, 22 Drawing Figures

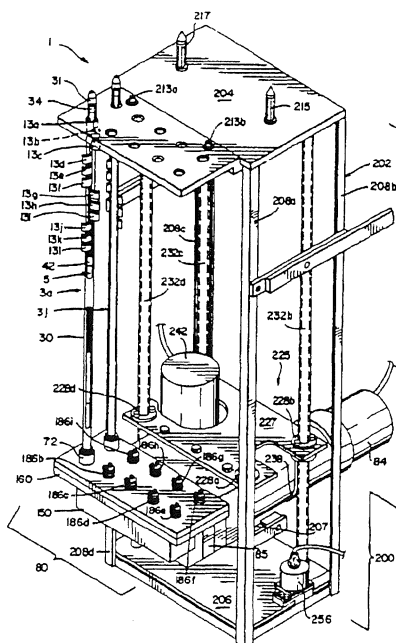

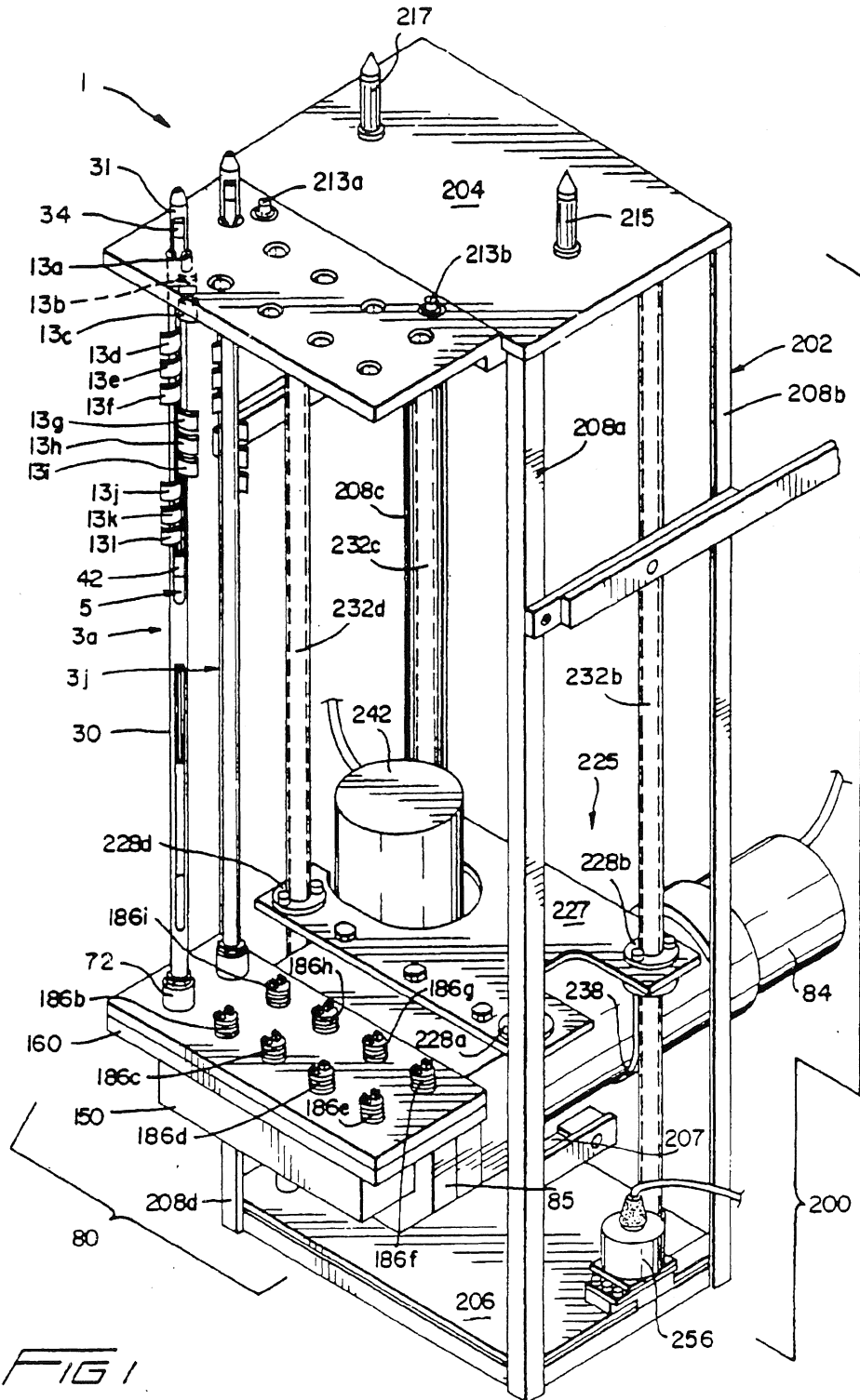

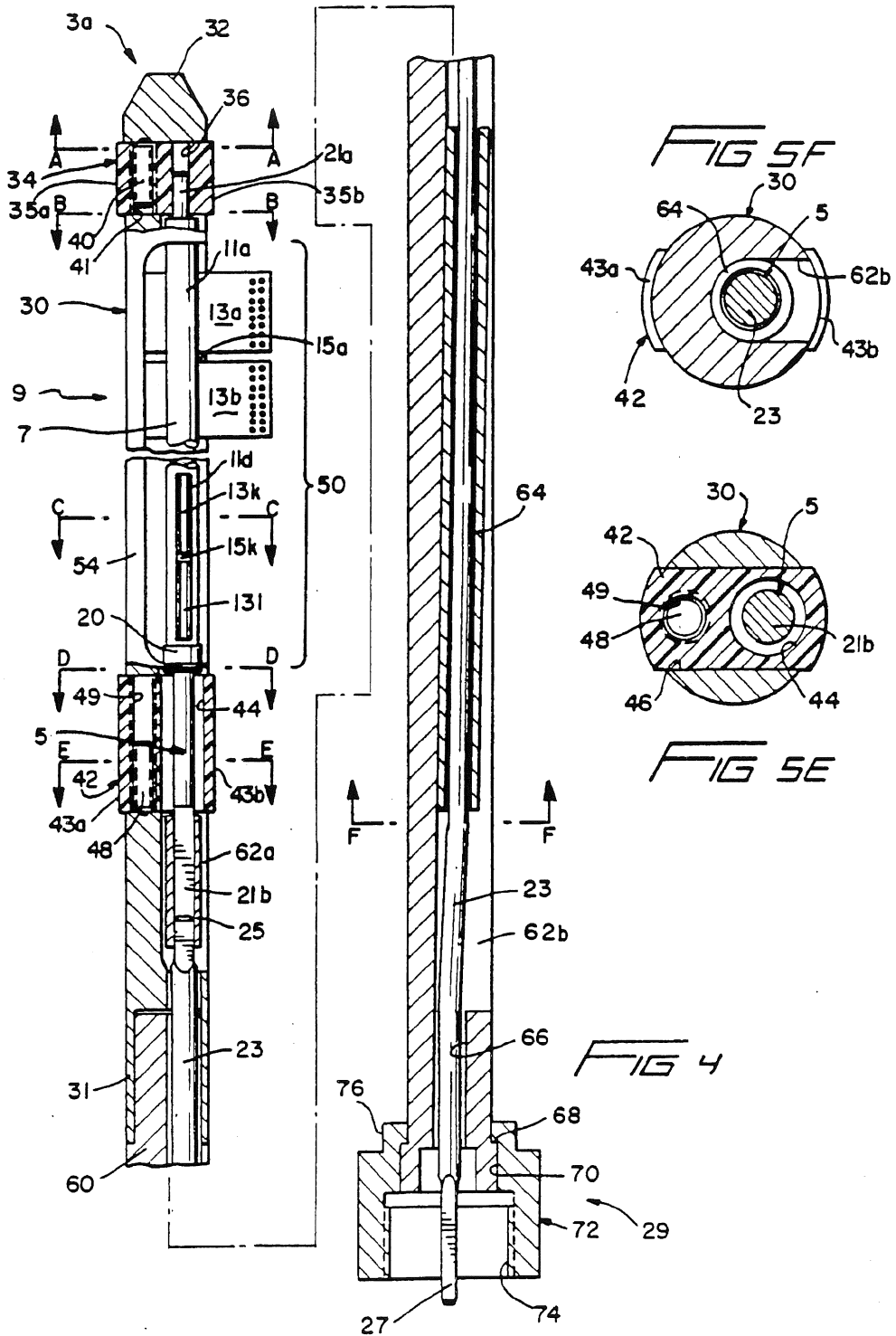

FIG 5D

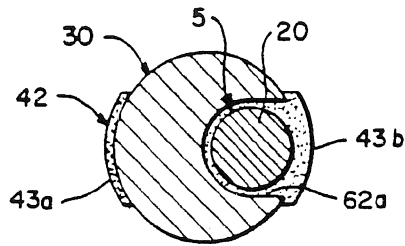

FIG 5C

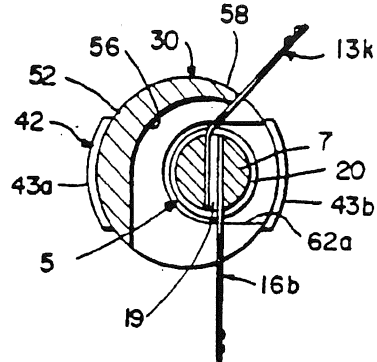

FIG 5B

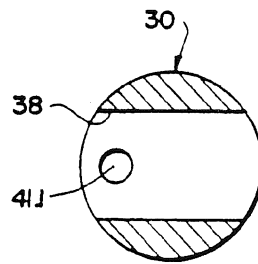
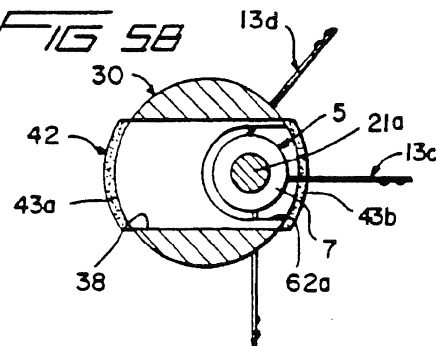

FIG 5A

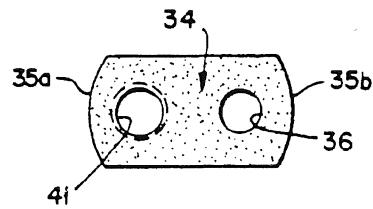

FIG 6A

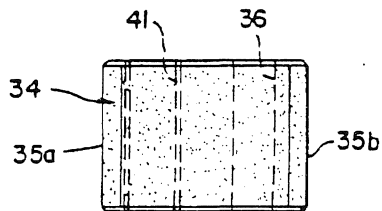

FIG 6B

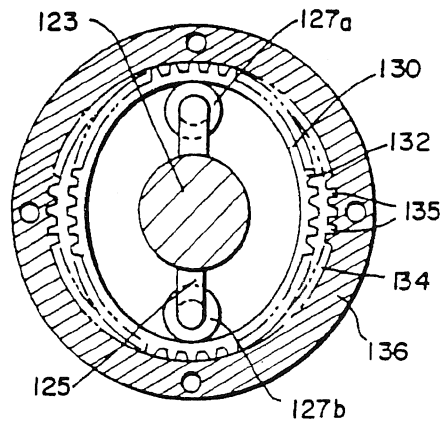

FIG 7B

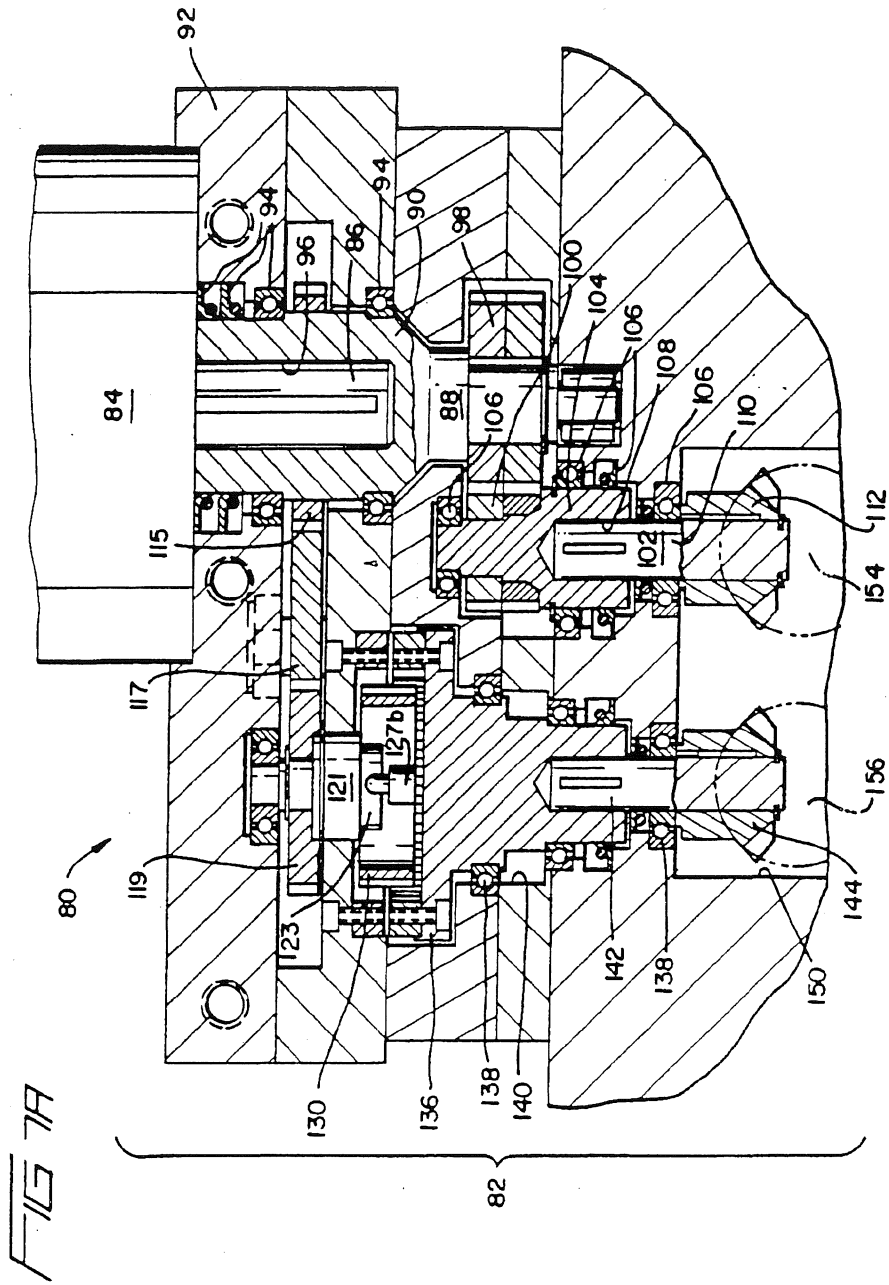
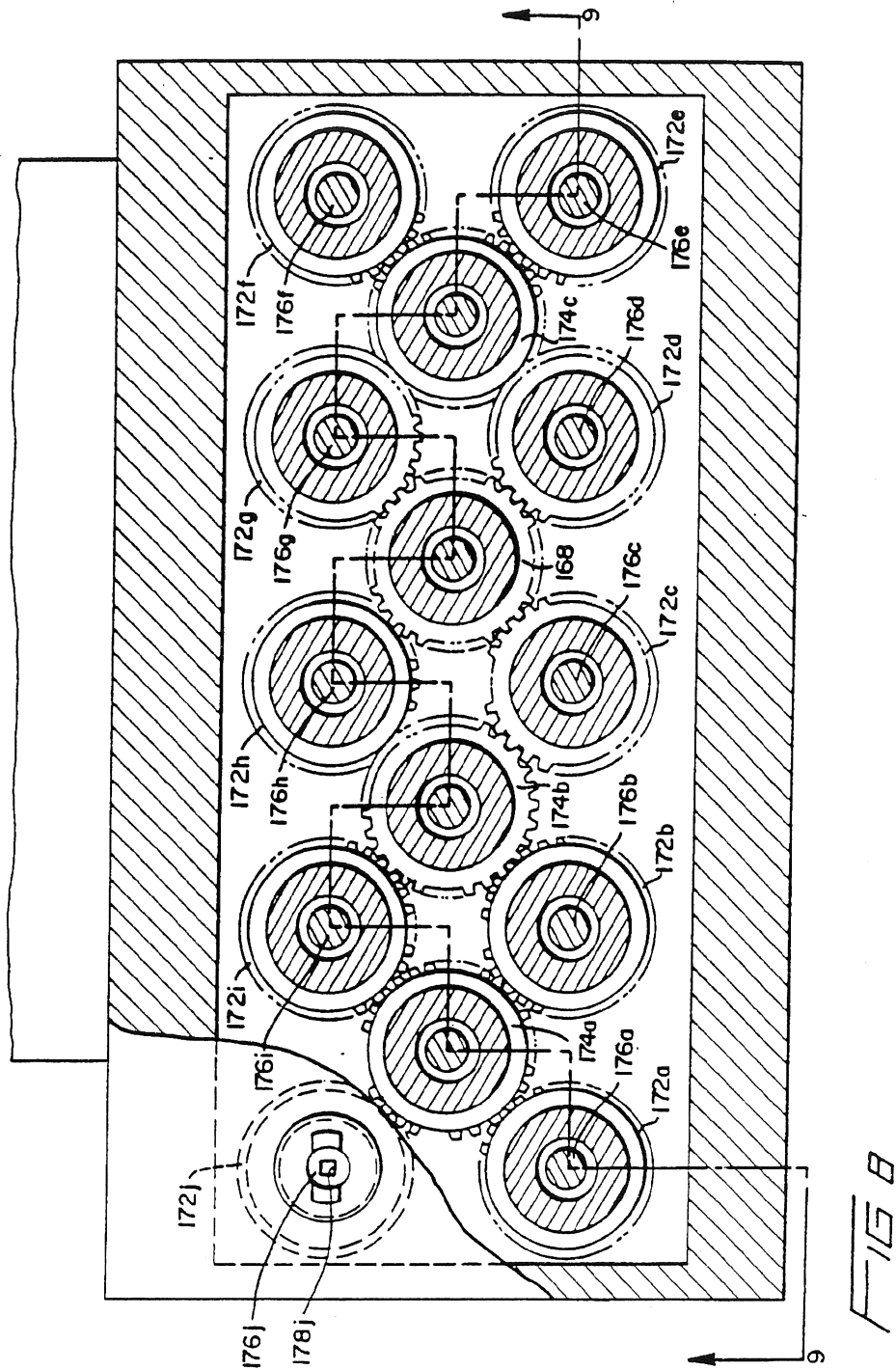

FIG 7A



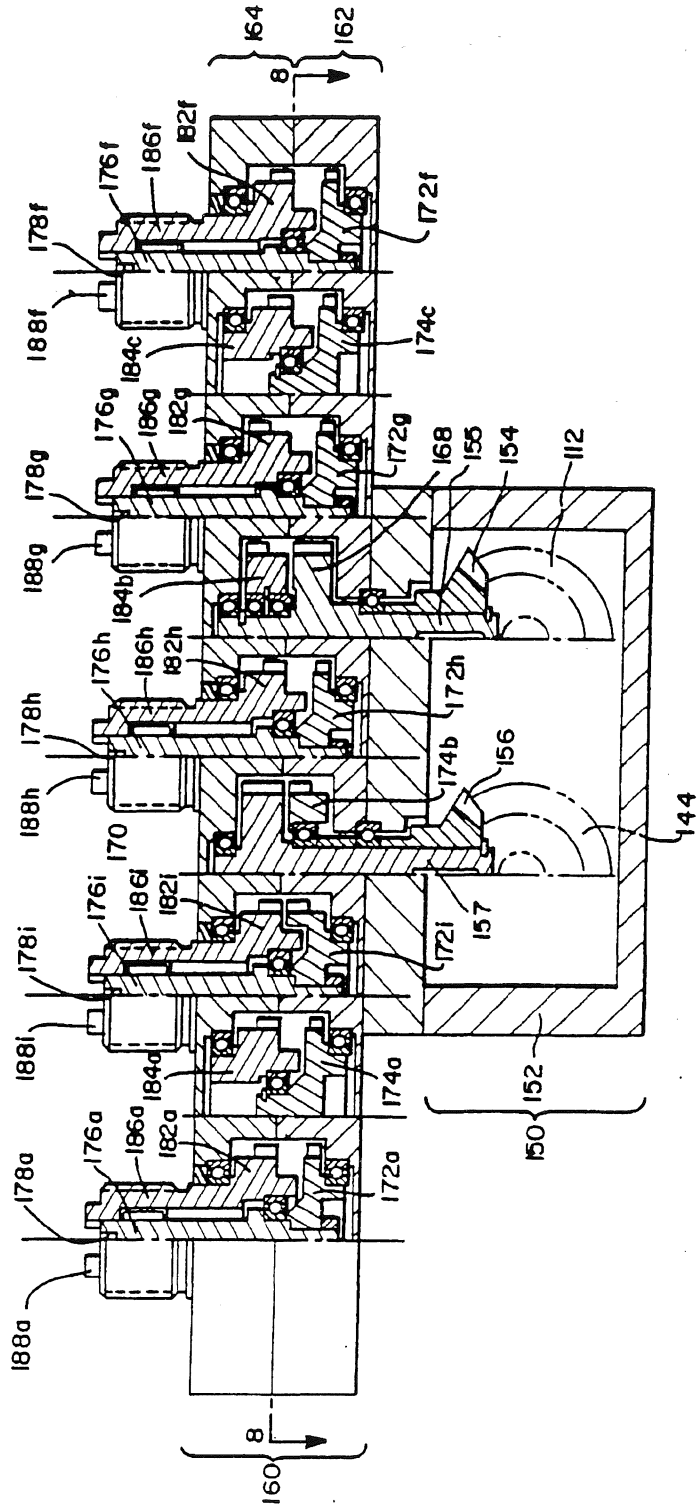
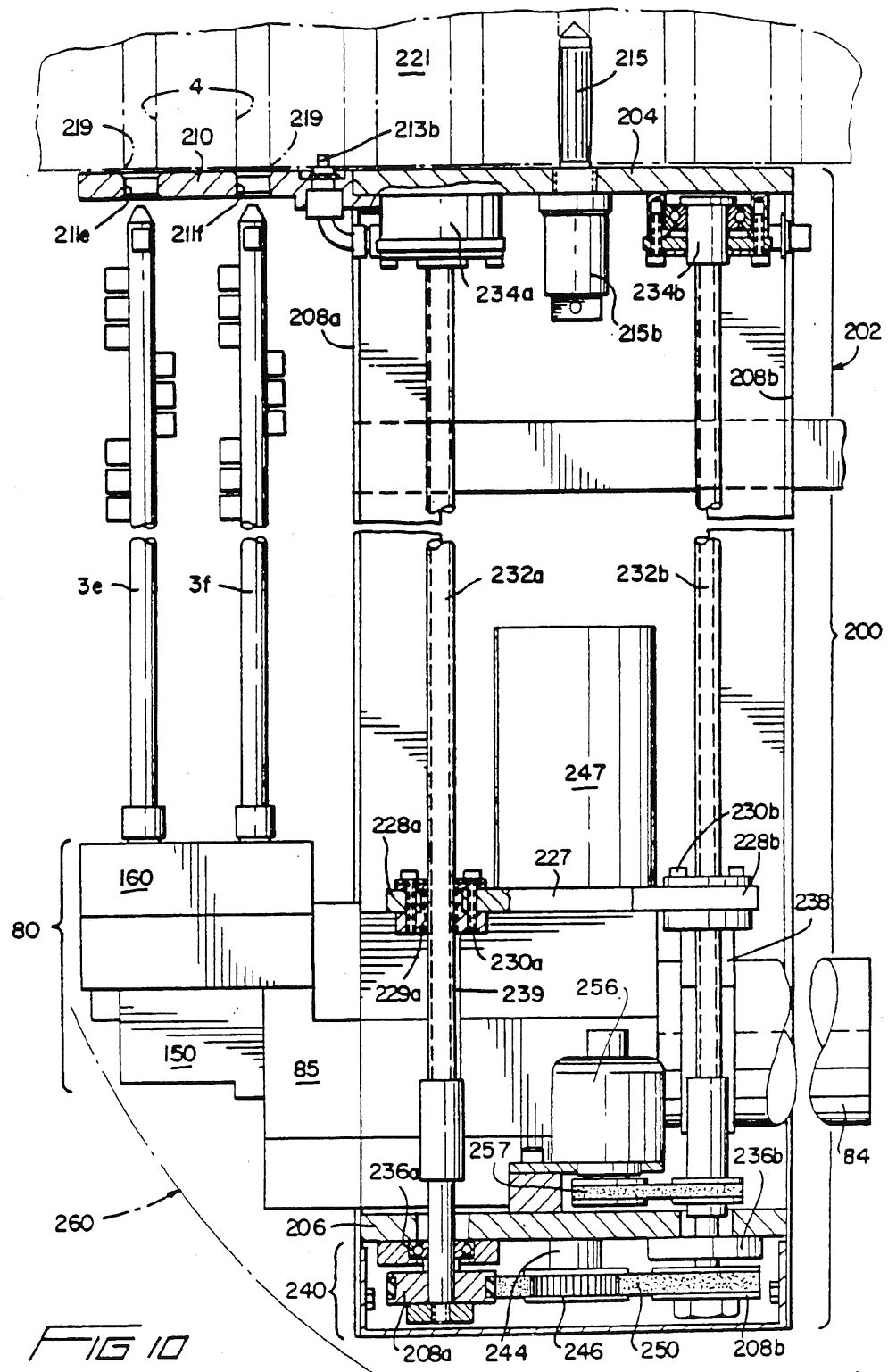

FIG 9



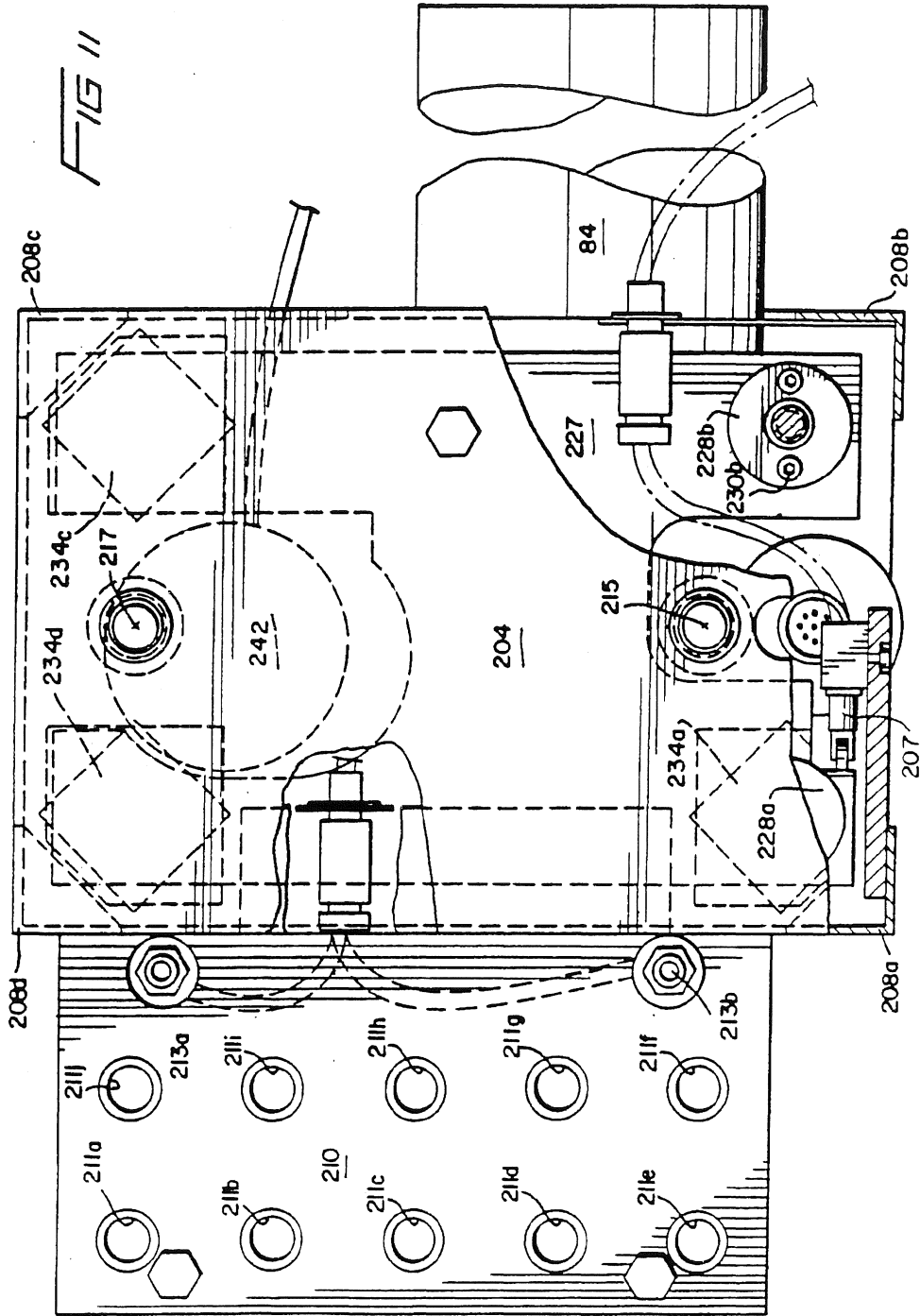

FIG 12

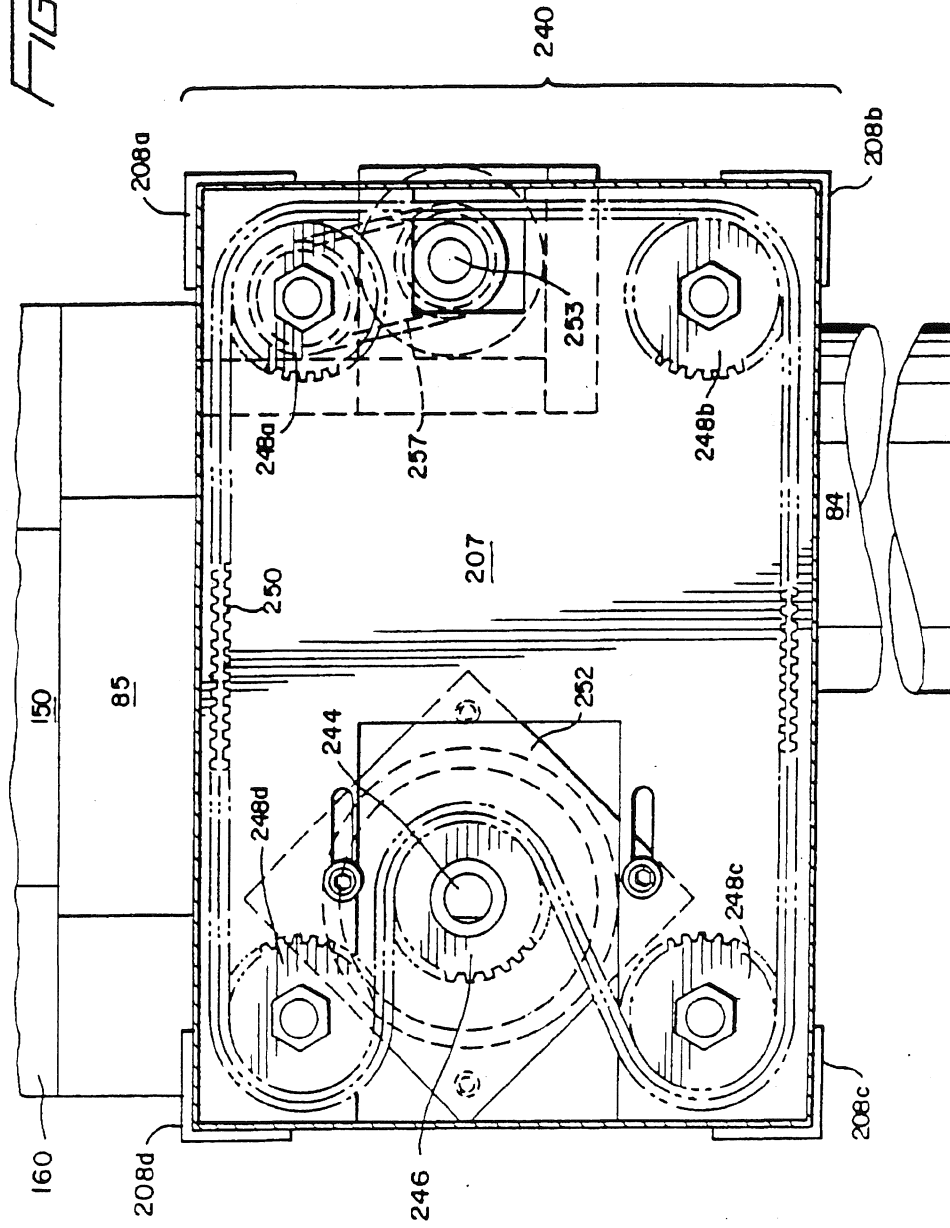

FIG 13

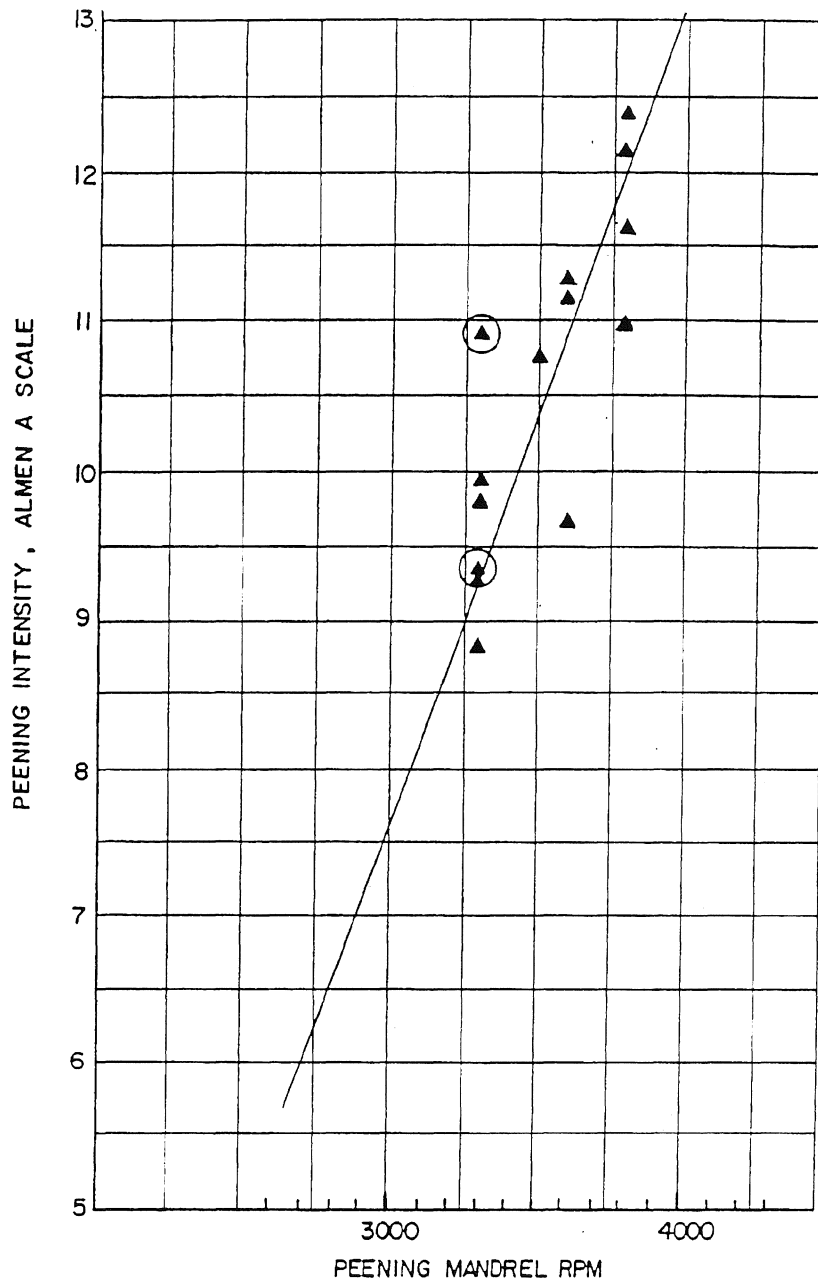
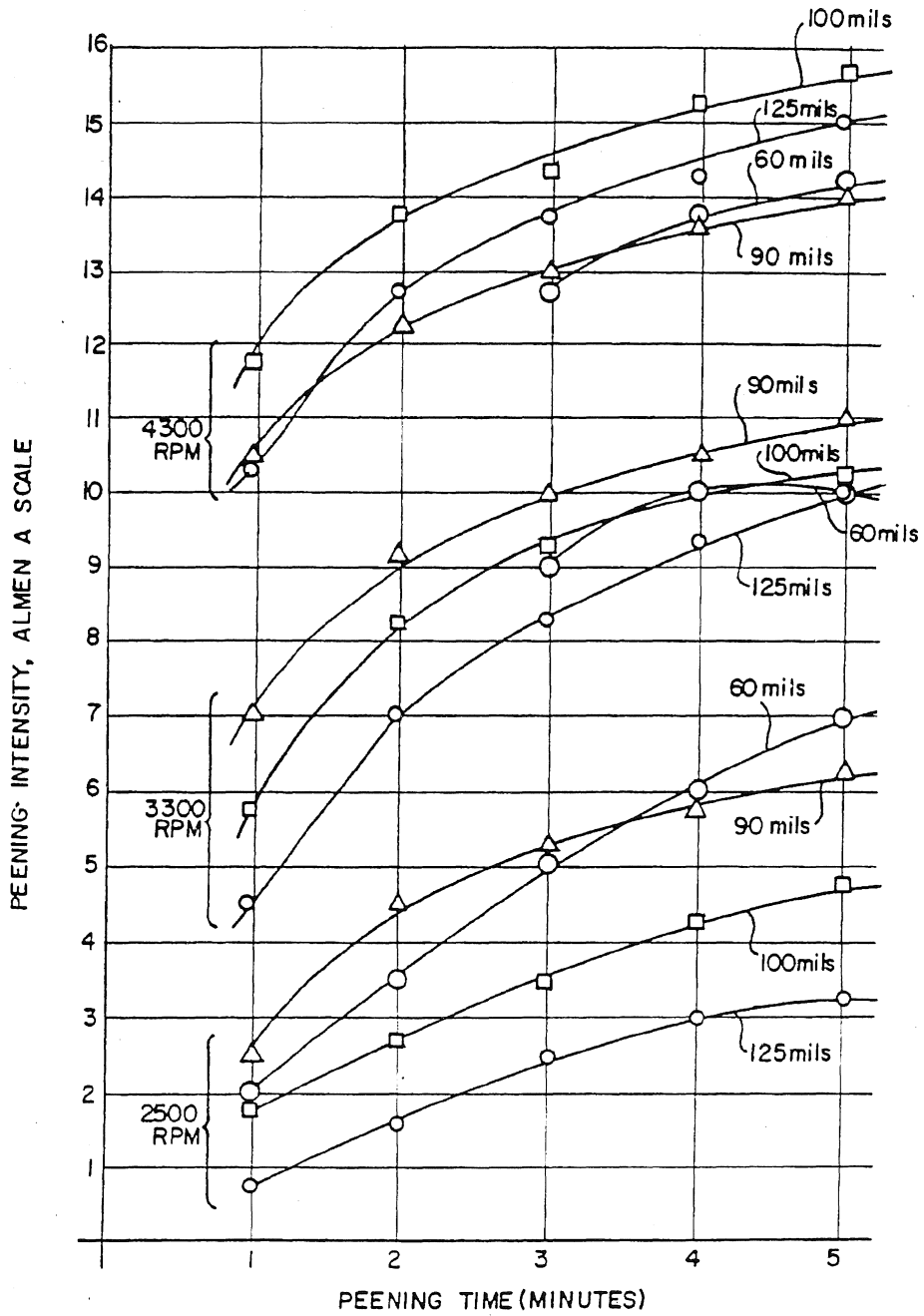

FIG 14



SPINDLE FOR ROTOPEENING APPARATUS

BACKGROUND OF THE INVENTION

1. Field of the Invention

This invention relates to peening devices capable of peening the interior walls of metallic tubes, thereby cold-working them. It is particularly useful in rotopeening heat exchange tubes mounted in the tubesheet of a nuclear steam generator in order to relieve stresses in the tubes.

2. Description of the Prior Art

Devices for peening the inside walls of metallic tubes are generally known in the prior art. Such devices are particularly useful in relieving or at least equilibrating the tensile stresses which may be induced across the wall of a metallic tube when that tube is radially expanded, as by a hydraulic mandrel or a cold-rolling tool. Such stress-causing expansions are routinely performed in the heat exchange tubes of nuclear steam generators, particularly in the sections of the tubes extending through the generator tubesheet, both during the manufacture and maintenance of the nuclear steam generator. Unfortunately, the resulting tensile stresses can lead to an undesirable phenomenon known as "stress corrosion cracking" in the tube walls if these stresses are not relieved. But in order to fully understand the dangers associated with such stress corrosion cracking, and the utility of the invention in preventing such cracking, some general background as to the structure, operation and maintenance of nuclear steam generators is necessary.

Nuclear steam generators are comprised of three principal parts, including a secondary side and a tubesheet, as well as a primary side which circulates water heated from a nuclear reactor. The secondary side of the generator includes a plurality of U-shaped tubes, as well as an inlet for admitting a flow of feedwater. The inlet and outlet ends of the U-shaped tubes within the secondary side of the generator are mounted in the tubesheet which hydraulically separates the primary side of the generator from the secondary side. The primary side in turn includes a divider sheet which hydraulically isolates the inlet ends of the U-shaped tubes from the outlet ends. Hot, radioactive water flowing from the nuclear reactor is admitted into the section of the primary side containing all of the inlet ends of the U-shaped tubes. This hot, radioactive water flows through these inlets, up through the tubesheet, and circulates around the U-shaped tubes which extend within the secondary side of the generator. The hot, radioactive water from the reactor transfers its heat through the walls of the U-shaped tubes to the non-radioactive feedwater flowing through the secondary side of the generator, thereby converting the feedwater to non-radioactive steam which in turn powers the turbines of an electric generator. After the water from the reactor circulates through the U-shaped tubes, it flows back through the tubesheet, through the outlets of the U-shaped tubes, and into the outlet section of the primary side, where it is recirculated back to the nuclear reactor.

The walls of the heat exchange tubes in such nuclear steam generators can suffer a number of different forms of corrosion degradation, including denting, stress corrosion cracking, intragranular attack, and pitting. In situ examination of the tubes within these generators has revealed that most of this corrosion degradation occurs in what are known as the crevice regions of the genera-

tor. The principal crevice region for each of the U-shaped tubes is the annular space between the heat exchange tube and the bore in the tubesheet through which the tube extends. Corrosive sludge tends to collect within this crevice from the effects of gravity. Moreover, the relatively poor hydraulic circulation of the water in this region tends to maintain the sludge in this annular crevice, and to create localized "hot spots" in the tubes adjacent the sludge. The heat radiating from these "hot spots" acts as a powerful catalyst in causing the exterior walls of the heat exchange tubes to chemically combine with the corrosive chemicals in the sludge.

While most nuclear steam generators include blow-down systems for periodically sweeping the sludge out of the generator vessel, the sludges in the tubesheet crevice regions are not easily swept away by the hydraulic currents induced by such systems. Despite the fact that the heat exchange tubes of such generators are typically formed from corrosion-resistant Inconel stainless steel, the combination of the localized regions of heat and corrosive sludge can ultimately cause the walls of the heat exchange tubes to crack, and to leak radioactive water from the primary side into the secondary side of the generator, thereby radioactively contaminating the steam produced by the steam generator.

In order to prevent such corrosion and tube-cracking from occurring in the annular crevices surrounding the tubes in the tubesheet, various processes have been developed for radially expanding the sections of the tubes extending through the tubesheets so as to eliminate the annular space between the bores in the tubesheet and the heat exchange tubes. Such radial expansions may be implemented by hydraulic mandrels capable of applying fluid pressures of near 10,000 psi across selected sections of the tubes, or by cold-rolling tools which utilize pitched, tapered rollers capable of screwing into the open ends of the tubes, thereby widening them. However, such tube expansions create tensile stresses throughout the walls of the tubes in the tubesheet region which render them more susceptible to corrosion, thereby partially defeating the purpose of the tube expansion. Because the metal around the inner diameter of the tube was expanded a relatively greater amount than the metal forming the outer diameter of the tube, most of the tensile stress caused by the radial expansion was concentrated in the inner wall of the tube.

In order to relieve this tensile stress, shot peening processes were developed for hardening the inner walls of the expanded tubes. Such shot peening processes generally employed a nozzle which was slidably insertable through the open ends of the tubes in the tubesheet and which was capable of radially firing a large volume of tiny zirconia balls against the inner wall of the tube. The resulting high-velocity impingement of the hard, zirconia "shot" relieved much of the stress in the tube walls by compressibly work-hardening the inner wall of the tube. Since stress corrosion (and consequent cracking) seems to occur only in those regions of the tube walls which have undergone a threshold stress of between 10 and 15 kilo-pounds per square inch, the relief of the regions suffering maximum stress to a level less than 10 kilo-pounds substantially reduced the likelihood of stress corrosion.

Unfortunately, such prior art shot-peening processes are not without shortcomings. For example, if the mo-

tion of the peening nozzle along the longitudinal axis of the tube is not carefully controlled, a non-uniform peening pattern may result in the interior wall of the tube. Worse yet, if the peening nozzle should accidentally remain stationary for any significant amount of time during the shot-peening process, the high-velocity balls of zirconia can create new stress patterns in the walls of the tube which exceed the threshold stress limit for stress corrosion cracking to occur, and can even break completely through the tube walls, depending upon how long they remain stationary within the tube. Still other problems arise from the fragmented zirconia which becomes stuck in the inner walls of the tubes. Such fragments must be cleaned out of these tubes by means of a rotating, abrasive tool. This not only necessitates another time-consuming (and hence expensive) step in the maintenance procedure, but also creates a cloud of radioactive zirconia dust which may contaminate non-radioactive areas of the plant if this dust is not captured and disposed of properly. Additionally, the constant recirculation of the peening shot tends to change its peening characteristics, which in turn adversely affects the uniformity of the peening pattern created in the inner walls of the tubes even when the nozzle is moved at a uniform speed through the tube. Finally, such shot-peening processes are generally capable of only peening one tube at a time, which again renders the process slow and expensive due to the large amount of plant "down-time" that the process necessitates.

Clearly, there is a need for a peening apparatus capable of uniformly peening the inner walls of the heat exchange tubes mounted within the tubesheet of a nuclear steam generator. Ideally, such an apparatus should be able to quickly and accuratelypeen the walls of such tubes in order to minimize the time (and hence the expense) of the peening procedure. Finally, such an apparatus should be able topeen the walls of such tubes without inducing other corrosion-inducing stresses in the tube wall, and without necessitating a separate abrasion step which creates a cloud of potentially-contaminating radioactive dust.

SUMMARY OF THE INVENTION

In its broadest sense, the invention is a rotopeening apparatus including a rotatable housing, a mandrel having at least one peening means, and means for rotatably mounting the mandrel within the housing in an off-center manner so that the peening means rotates and orbits within the conduit when the mandrel and housing are rotated.

The rotatable housing may include a cage formed from an open section and a ligment, and the peening means may include a plurality of peening flappers connected to the mandrel which are aligned with the open portion of the cage means when the mandrel is rotatably mounted within the housing. In the preferred embodiment, the rotatable housing is rigid in order that it may be easily aligned with and inserted into the open end of a conduit such as a tube mounted within the tubesheet of a nuclear steam generator.

The means for rotatably mounting the mandrel within the housing may include first and second bearings positioned at either ends of the cage means. Each bearing may include a bore which is radially displaced relative to the longitudinal axis of the housing for receiving the ends of the longitudinal section of the mandrel bearing the peening flappers. The bearings may

serve the additional function of maintaining the stand-off distance between the peening flappers and the interior wall of the tube being peened. In the preferred embodiment, the outer diameters of each of the bearings are slightly larger than the outer diameter of the rotatable housing in order that the bearings might engage the inner wall of the tube being peened in a "running fit" within fairly tight tolerances, so that a selected stand-off distance between the peening flappers and the inner wall of the tube can be maintained. It should be noted that the enlarged, outer diameters of the bearings not only allow them to maintain a desired stand-off distance, but also isolate the outer surface of the rotatable housing from frictional engagement with the inside wall of the tube.

Each of the peening flappers is preferably angularly and axially displaced from each of the peening flappers adjacent thereto in order to reduce the wind resistance of the flapper configuration, which in turn reduces the power consumption of the apparatus. Additionally, the ligament forming the cage in the housing preferably has an internal cavity with a spiral cross-section for receiving the flappers in riding engagement on its leading edge, and for guiding the flappers into a whipping motion against the inner wall of the tube on its trailing edge. Finally, the leading edge of the ligament is rounded in order to minimize any erosive, peening action the flappers may render on the ligament.

BRIEF DESCRIPTION OF THE SEVERAL FIGURES

FIG. 1 is a perspective view of the preferred embodiment of a multi-spindle, rotopeening apparatus which utilizes the rotopeening spindles of the invention;

FIG. 2 is a perspective view of one of the rotopeening spindles of the invention;

FIGS. 3A and 3B are cross-sectional views of the cage of the peening spindle illustrated in FIG. 2, showing how the peening flapper is attached to the rotating and orbiting mandrel journaled within the spindle whippingly strike the inside wall of a tube being peened;

FIG. 4 is a partial, cross-sectional side view of the spindle illustrated in FIG. 2;

FIGS. 5A, 5B, 5C, 5D, 5E and 5F are cross-sectional views of the spindle illustrated in FIG. 4 across sections AA, BB, CC, DD, EE and FF;

FIGS. 6A and 6B are top and side views of the self-lubricating plastic bearings which journal the mandrel of the spindle across the peening cage in an off-center fashion;

FIG. 7A is a cross-sectional plan view of the input gear assembly of the rotary and orbital drive assembly of the rotopeening apparatus which utilizes the spindles of the invention;

FIG. 7B is a cross-sectional side view of the harmonic drive assembly used in the input gear assembly;

FIG. 8 is a partial, cross-sectional plan view of the multi-spindle output gearbox of the rotary and orbital drive assembly;

FIG. 9 is a partial, cross-sectional side view of the multi-spindle output gearbox illustrated in FIG. 8;

FIG. 10 is a partial, cross-sectional side view of the oscillatory drive assembly of the apparatus utilizing the spindles of the invention;

FIG. 11 is a partial, cross-sectional plan view of the drive assembly of FIG. 10;

FIG. 12 is a partial, cross-sectional bottom view of this drive assembly;

FIG. 13 is a graph illustrating the relationship between the peening mandrel rpms and the resulting peening intensity after four minutes, and

FIG. 14 is a graph illustrating the relationship between the rate at which a given peening intensity is achieved at various mandrel rpms and various stand-off distances.

DETAILED DESCRIPTION OF THE PREFERRED EMBODIMENT

General Overview of the Structure and Function of the Invention

With reference to FIG. 1, wherein like numerals designate like components throughout all of the several Figures, the peening spindles 3a-3j of the invention are preferably used in conjunction with a multi-spindled rotopeening device 1. Each of the spindles 3a-3j includes a rotatable mandrel 5 which holds at least twelve peening flappers 13a-13j. Each of the spindles 3a-3j further includes a spindle housing 30 having a top cylindrical housing 31 which is provided with a cage 50. As will be described in more detail hereinafter, the cage 50 of each of the spindles 3a-3j maintains the alignment between a pair of plastic, self-lubricating bearings 34, 42 which journal the mandrel 5 in an off-center manner relative to the longitudinal axes of the spindles 3a-3j, and control the stand-off distance between the peening balls 18 and the inner wall of the tube being peened.

Both the mandrel 5 and the top cylindrical housings 31 of each of the spindles 3a-3j are detachably coupled to a rotary and orbital drive assembly 80. This rotary and orbital drive assembly 80 has a drive train 82 formed from an electric motor 84, an input gear assembly 85, a miter gearbox 150 and a multi-spindle output gearbox 160. The output gearbox 160 in turn includes ten rotary output shafts 176a-176j which are concentrically disposed within ten orbital output shafts 186a-186j (as best seen in FIG. 9) for rotating and orbiting the mandrels 5 and the cages 50 of each of the spindles 3a-3j, respectively. The square (or triangular) pitch of the orbital output shafts 186a-186j is preferably equal to the square (or triangular) pitch of the heat exchange tubes 4 mounted in the tubesheet 221 of a nuclear steam generator in order that the spindles 3a-3j may simultaneously rotopeen ten contiguous tubes 4 within the tubesheet 221.

The last principal component of the multi-spindle rotopeening device 1 is the oscillatory drive assembly 200. This drive assembly 200 includes a frame 202 having rectangular top and bottom support plates 204, 206 connected together at their corners by means of angular leg members 208a-208d. The top support plate 204 includes a guide plate 210 having an array of apertures 211a-211j for registering and guiding the ends of the spindles 3a-3j into the open ends of the tubes 4 in the tubesheet 221. The top support plate 204 also includes a pair of expandable collets 215, 217 insertable within the open ends 219 of the tubes 4 for mounting the array of apertures 211a-211j into registry with the open ends 219 of the tubes 4. Finally, this component includes an indexing and reciprocating mechanism for vertically translating and oscillating the rotary and orbital drive mechanism 80 (and the rigid spindles 3a-3j within the tubes 4) as the peening flappers 13a-13j are forcefully whipped against the inner walls of these tubes 4. This indexing and reciprocating mechanism 225 generally includes a saddle plate 227 which supports the rotary and oscillatory drive assembly 80 within the frame 202

by means of a U-shaped bracket 238. The saddle plate 227 includes four bronze nut assemblies 228a-228d in each of its corners. These nut assemblies 228a-228d are threadedly engaged to four threaded, rotatable rods 232a-232d. Each of the rods 232a-232d is journaled at its top and bottom ends to the rectangular top and bottom support plates 204 and 206 of the frame 202, and each may be simultaneously rotated either clockwise or counterclockwise by means of a rod rotating assembly 240. When the rods 232a-232d are simultaneously rotated, the rotary and oscillatory drive assembly 80 is translated or oscillated within the frame 202 in "riding nut" fashion.

Specific Description of the Structure and Function of the Invention

With reference now to FIGS. 2, 3A, 3B and 4, each of the rigid spindles 3a-3j contains a rotatable mandrel 5 which is journaled in an off-center relationship with respect to the longitudinal axis of its respective spindle. The mandrel 5 of each of the spindles 3a-3j includes a rigid, enlarged section 7 near the distal end 9 of the spindle. This enlarged section 7 includes four slots 11a-11d for receiving and holding the twelve peening flappers 13a-13j in four groups of three. As is evident from FIGS. 2 and 4, each of these slots 11a-11d is orthogonally disposed with respect to its neighbors. Additionally, a small gap 15a-15j is interposed between each of the flappers 13a-13j. Such gapping advantageously reduces the air resistance of the flappers, and hence reduces the amount of mandrel torque needed to peen at a given level. While the gaps illustrated in FIGS. 2 and 4 are small relative to the length of the flaps 13a-13j, they may be as wide as the flaps themselves so long as the amplitude of the oscillatory movement (discussed in detail hereinafter) is lengthened commensurately. As is best seen with respect to FIGS. 3A and 3B, each of the peening flappers 13a-13j includes a pair of rectangular flap leaves 17a, 17b. Each of the flap leaves 17a, 17b in turn includes an array of peening balls 18 on its outer edge. In the preferred embodiment, two rows consisting of eight peening balls each are mounted on the outer edges of the flap leaves 17a, 17b. The peening balls 18 are preferably about 1/40,000ths of an inch in diameter, and are formed from a hard material such as tungsten carbide. Each of the flap leaves 17a, 17b is preferably formed from a flexible composite of fiberglass and epoxy resin. Additionally, the inner edges of each of the flap leaves 17a, 17b are preferably laminated over a resilient mounting pad 19. The thickness of the laminate formed by the mounting pad 19 and the two outer edges of the flap leaves 17a, 17b is slightly greater than the thickness of each of the slots 11a-11d so that the peening flappers 13a-13j may be frictionally secured within the slots 11a-11d by merely inserting the laminated mounting plate 19 into its respective slot in the position illustrated in FIGS. 3A and 3B. Flappers conforming to the aforementioned specifications are available from the Building Service and Cleaning Products Division of Minnesota Mining & Manufacturing Company of Cleveland, Ohio.

With reference now to FIG. 4, the rigid, enlarged section 7 of the mandrel 5 includes an axle portion 20 near its proximal end, and terminates in a shaft portion 21a at its distal end. Shaft portion 21a and axle portion 20 journal the rigid, flapper-containing section 7 of the mandrel within the self-lubricating bearings 34 and 42,

respectively. Each of these bearings 34 and 42 includes a bore 36 and 44 for receiving the shaft portion 21a and axle portion 20 of the enlarged section 7 of the mandrel 5, respectively. Instead of being concentrically aligned with the longitudinal axis of the spindle 3a, these bores 36 and 44 are deliberately radially displaced from the longitudinal axis of the spindle 3a so that the enlarged section 7 is journaled within the spindle 3a in an off-center relationship. Directly behind axle portion 20 is coupling portion 21b which serves to connect the rigid, enlarged section 7 of the mandrel 5 with a flexible section 23 of the mandrel 5 formed from a flexible, right-hand, drive-type coupling material having a 0.150 inch core diameter. Such flexible coupling material is available from Stow Manufacturing Company of Binghamton, N.Y. The shaft portion 21b of the rigid, enlarged section 7 is connected to the flexible section 23 of the mandrel 5 by means of a cylindrical coupling 25 which is rotatable within a U-shape cavity 62a. As is best seen in FIG. 4, this flexible section 23 of the mandrel 5 terminates in a rigid, square shaft 27 at its proximal end.

Each of the spindles 3a-3j includes a rigid spindle housing 30 formed from a top cylindrical housing 31 which is screwed into a bottom cylindrical housing 60. The outer diameter of both the top and bottom cylindrical housings 31 and 60 is somewhat less than the inner diameter of the wall of the tubes 4 being peened so that the spindles 3a-3j may be easily inserted into and withdrawn from the open ends 219 of these tubes 4. At its distal end 9, the top cylindrical housing 31 terminates in an end portion 32 which is tapered to facilitate the insertion of the end of the spindle 3a into the mouth of a tube 4. Immediately under the tapered end portion 32 is the previously mentioned self-lubricating bearing 34. In the preferred embodiment, bearing 34 is formed from an easily machined, self-lubricating plastic such as Delrin®. As is best seen with respect to FIGS. 5A, 6A and 6B, bearing 34 is generally shaped like a rectangular prism whose shortest sides 35a, 35b are arcuate in shape. The maximum outer diameter of bearing 34 is chosen so that it is less than the inner diameter of the tubes 4 to be rotopeened, but greater than the outer diameter of the spindle housing 30. Such dimensioning prevents metal-to-metal frictional engagement between the outer surface of the spindle housing 30 and the inner surface of the tube 4 by confining all such frictional contact to a running engagement between the tube surface and the arcuate sides 35a, 35b of the self-lubricating bearing 34 (and the arcuate walls 43a, 43b of the self-lubricating bearing 42 located beneath the bearing 34). Bearing 34 is seatable within a complementary slot 38 located near the distal end 9 of the top cylindrical housing 31. In order that bearing 34 may be positively retained in this complementary slot 38, a spring-loaded detent peg assembly 40 is provided therein. Peg assembly 40 has a threaded exterior which may be screwed into a bore 41 within the bearing 34. Thus positioned, the peg of the peg assembly 40 may be "snap-fitted" into a circular recess 41.1 located within the top cylindrical housing 31 when the bearing 34 is seated within slot 38.

Peening spindle 3a further includes a second self-lubricating bearing 42 which is quite similar both in structure and function to the bearing 34. Bearing 42 is preferably also made of a self-lubricating and easily machinable plastic such as Delrin®, and includes the previously mentioned bore 44 for journaling the axle portion 20 of the enlarged, rigid portion 7 of the mandrel 5. Most importantly, bearing 42 has arcuate walls

43a, 43b which are dimensioned the same as the arcuate walls 35a, 35b of bearing 34 in order that the two bearings 34 and 42 coacting together may successfully prevent any portion of the outer surface of spindle housing 30 from coming into frictional contact with the inner wall of the tube 4 being peened. Finally, bearing 42 likewise contains a spring-loaded detent peg assembly 48 which is threaded along its exterior surface in order that it might be screwed into bore 49. The peg of the spring-loaded detent peg assembly 48 may be "snap-fitted" into a circular recess (not shown) when the bearing 43 is seated within complementary slot 46. Directly below bearing 42 is a U-shaped cavity 62a which houses the cylindrical coupling 25 of the mandrel 5.

FIGS. 3A, 3B and 4 best illustrate the cage 50 of the top cylindrical housing 31 of the spindle 3a. Generally, the cage 50 consists of a ligament portion 52 having a semicircular exterior 54, and a spiral-shaped cavity 56 which terminates in a flap-receiving rounded edge 58. The ligament portion 52 maintains the alignment between the bores 36 and 44 in the bearings 34, 42 during the operation of the spindle 3a by providing both integrity and rigidity to the spindle housing 30. The ligament portion 52 achieves this function with a minimum amount of erosive peening action between it and the peening balls 18 of the flappers 13a-13j by virtue of the shape of its spiral cavity 56. The interaction between the cavity 56 of the ligament portion 52 and the leaves 17a, 17b of the peening flappers 13a-13j is best understood with specific reference to FIGS. 3A and 3B. In FIG. 3A, peening flapper 17a approaches the flap-receiving rounded edge 58, while the peening balls 18 of flap leaf 17b begin to ride on the portion of the spiral cavity 56 having the smallest radius. The rigid portion 7 of the mandrel 5 is, of course, rotating counterclockwise in both of these Figures. The centripetal force imparted to the peening balls 18 of the flapper leaf 17b by the spinning mandrel 5 causes these balls 18 to ride completely around the spiral-shaped cavity 56 of the ligament portion 52, and "whip" into the wall of the tube 4 in the position shown in FIG. 3B. As will be described in more detail hereinafter under the "process description" section, the angular speed imparted to the peening balls 18 from the rotating mandrel 7 is sufficiently great enough so that the balls 18 effectively cold-work the inner wall of the tube 4 when they strike it, thereby relieving tensile stresses around the inner diameter of the tube 4. At about the same time the peening balls 18 of the flapper leaf 17b whipingly strike the inner wall of the tube 4, the opposing flapper leaf 17a has engaged the flap-receiving rounded edge 58 of the ligament 52, and begun to "ride" along the spiralled contour of cavity 56. In the preferred embodiment, edge 58 is rounded as shown instead of sharply tapered. Surprisingly, the applicants have found that a rounded edge is more resistant to wear from the peening balls 18 than a knife-type edge. While the mandrel 5 rotates the peening flappers 13a-13j, the cage 50 also rotates counterclockwise about the longitudinal axis of the tube 4, thereby imparting an orbital component of motion to the rigid, enlarged section 7 of the mandrel 5. This orbital motion allows the peening balls 18 to uniformly strike every point around the circumference of the inner wall of the tube 4. The orbital component of motion may be seen by comparing the orbital position (x) of the mandrel 5 and the ligament 52 in FIG. 3A with the orbital position (x') of these components in FIG. 3B. In reality, this orbital component of motion is much smaller than the rota-

tional component of motion of the mandrel 5 than the drawings of FIGS. 3A and 3B indicate. Specifically, the mandrel 7 rotates at 3,000 to 3,300 rpms, while the cage 50 of the spindle 3a rotates at only about 14 to 17 rpms. As has been previously indicated, as the spindle housing 30 rotates within a tube 4, the outer surfaces of self-lubricating bearings 34 and 42 contact the inner walls of the tube in running engagement. Because the outer diameters of the self-lubricating bearings 34, 42 are chosen so as to be only slightly smaller than the inner diameter of the tube 4, the two bearings 34, 42 maintain a uniform stand-off distance between the peening leaves 17a, 17b of the flappers 13a-13j as the spindle housing 30 rotates within the tube 4.

With reference again to FIG. 4, and to FIG. 5F, the peening spindle 3a further includes a bottom cylindrical housing 60 whose distal end is threadedly engageable with the proximal end of the top cylindrical housing 31. The bottom cylindrical housing 60 includes a U-shaped mandrel housing cavity 62b which communicates with the U-shaped cavity 62a of the top cylindrical housing 31. This U-shaped cavity becomes gradually deeper along the longitudinal axis of the spindle housing 30, and terminates in a mandrel shaft bore 66 which is concentrically disposed within the proximal end 29 of the bottom cylindrical housing 60. In its central section, the U-shaped cavity 62b includes a guide sleeve 64 through which the flexible section 23 of the mandrel extends. The guide sleeve 64 is welded or otherwise affixed within the U-shaped cavity 62b, and the flexible section 23 of the mandrels is freely rotatable within this sleeve 64. The general function of the gradually deepening U-shaped cavity 62b and the guide sleeve 64 is to reorient the flexible section 23 of the mandrel 5 from a concentric alignment with the longitudinal axis of the spindle housing 30, to an off-center alignment with the spindle housing 30 which is consummated at the point where the flexible section 23 of the mandrel is coupled to the shaft portion 21b of the rigid, enlarged section 7 of the mandrel 5. As has been previously indicated, such an off-center alignment is necessary if the peening flappers 13a-13j are to interact properly with the spirral cavity 56 of the cage ligament 52, and whipingly strike against the inner wall of the tube 4. The proximal end 29 of the bottom cylindrical housing 60 terminates in an enlarged annular shoulder 68. Although not specifically shown in FIG. 4, the bottom section of this enlarged shoulder 68 includes a pair of opposing slots for receiving key members extending from the orbital output shafts 186a-186j of the output gearbox 160. The enlarged shoulder 68 is rotatably captured within a complementary annular recess 70 located at the upper end of a spindle socket 72. The spindle socket 72 has a threaded interior 74 in order that it may be screwed onto the threaded exterior of the orbital output shafts 186a-186j. As will become more evident hereinafter, when the spindle sockets 72 of the spindles 3a-3j are threadably joined to the orbital output shafts 186a-186j, the square ends 27 of the mandrels 5 are seated into complementary, square recesses concentrically located within the rotary output shafts 186a-186j.

Turning now to FIGS. 1, 7A and 7B and the rotary and oscillatory drive assembly 80 of the multi-spindle rotopeening device 1, drive assembly 80 has a drive train 82 formed from an electric motor 84, an input gear assembly 85, a miter gearbox 150, and the previously mentioned output gearbox 160.

With specific reference now to FIG. 7A, the electric motor 84 includes a drive shaft 86 which is mechanically connected to a drive gear assembly 88 as indicated. In the preferred embodiment, electric motor 84 is a Model 1960, 120-volt, 60 Hz type synchronous motor manufactured by Aerotech-Unidex Corporation of Pittsburgh, Pa. The drive gear assembly 88 includes a shaft 90 which is rotatably mounted within the casing 92 of the input gear assembly 85 by means of ball bearings 94. The shaft 90 of the drive gear assembly 98 has a centrally disposed bore 96 for receiving the drive shaft 86 of the electric motor 84. In operation, the drive shaft 86 rotates the shaft 90 of the drive gear assembly 88 at approximately 1,550 rpms.

Concentrically mounted around the shaft 90 of the drive gear assembly 98 are a rotary mandrel drive gear 98, and an orbital mandrel drive gear 115. The teeth of the rotary mandrel drive gear 98 mesh with the teeth of a speed doubler gear 100, which doubles the angular speed of the shaft 90 from 1,550 rpms to 3,100 rpms. The speed doubler gear is in turn concentrically affixed around the shaft 104 of the miter gear assembly 102. The shaft 104 is journaled within the casing 92 of the input gear assembly 85 and the housing 152 of the miter gearbox 150 by means of ball bearings 106. Shaft 104 has a bore 108 for concentrically receiving the shaft 110 of a miter gear 112. Miter gear 112 serves the function of reorienting the 3,100 rpm output of the speed doubler gear 100 from a horizontal to a vertical direction.

Turning now to the previously mentioned orbital mandrel drive gear 115, the teeth of this gear mesh with the teeth of an idler gear 117 which in turn meshes with the teeth of the input gear 119 of a harmonic drive assembly 121. As may best be seen with respect to both FIGS. 7A and 7B, input gear 119 is concentrically affixed around the input shaft 123 of the harmonic drive assembly 121. This input shaft 123 is connected to a yoke 125 whose ends terminate in a pair of opposing rollers 127a, 127b. These rollers 127a, 127b in turn engage against the interior wall of a flexible gear ring or spine 130, known as a "wave generator" in the mechanical gear arts. The flexible gear ring 130 includes a plurality of gear teeth 132 on its outer surface which periodically intermesh with the teeth 135 of a rigid gear spine 134 (which is shaped like a planetary holder gear). The rigid gear spine 134 is in turn connected to an output shaft 136 which is rotatably mounted within both the casing 92 of the input gear assembly 85 and the housing 152 of the miter gearbox 150 by means of bearing 138. Output shaft 138 includes a centrally disposed bore 140 for receiving the shaft 142 of the miter gear 144. Miter gear 144, like neighboring miter gear 112, serves the function of reorienting the rotational output of the harmonic drive assembly 121 from a horizontal to a vertical direction. Because the orbital mandrel drive gear 115 and the input gear 119 of the harmonic drive assembly 121 are the same diameter, the input shaft 123 rotates at the same speed as the output shaft 86 of electric motor 84 (i.e., at 1,550 rpms). However, because the ratio of the teeth 132 and 135 on the flexible gear ring 130 and rigid gear spine 134 are selected so that the output rpms are only 1/100th of the input rpms, the angular speed of miter gear 144 is only about 15.5 rpms.

While harmonic drive assembly 121 resembles in many respects a conventional planetary gear assembly, its operation is fundamentally different, in that 360° rotation of the yoke 125 within the flexible gear ring or spine 130 advances the rigid gear spine an angular dis-

tance equal to only about one gear tooth. In more abstract terms, the ratio of transfer of rpms between the input and output shafts of the harmonic drive assembly follows the same waveform as the phenomenon of "beats" formed from a composite of two sound frequencies where one is slightly greater or less than the frequency of the other. Hence, the closer the ratio of the gear teeth of the flexible gear ring or spine 130 to the gear teeth in the rigid gear spine 134 approaches "1", the greater the ratio between the rpms of the input shaft and the output shaft of the harmonic drive assembly 121. In the preferred embodiment, the harmonic drive assembly 121 is a Model HDUF 20 (100:1) manufactured by Emhart Corporation of Wakefield, Md.

With reference now to FIGS. 7A and 9, the miter gearbox 150 of the rotary and oscillatory drive assembly 80 is formed from a housing 152 which contains an input rotary miter gear 154 attached to an output shaft 155, as well as an input orbital miter gear 156 which is similarly connected to another output shaft 157. The teeth of the input rotary miter gear 154 and the input orbital miter gear 156 mesh with the teeth of rotary drive miter gear 112 and the orbital drive miter gear 144. As indicated previously, the function of the pairs of miter gears 112, 154 and 144, 146 is to reorient the rotary and orbital drive trains 90° from the orientation of the output shaft 86 of the electric motor 84 from a horizontal to a vertical direction.

FIGS. 8 and 9 illustrate the output gearbox 160 of the rotary and oscillatory drive assembly 80. The output gearbox 160 includes a lower level of gears 162 for driving the rotary output shafts 176a-176j, and an upper level of gears 164 for driving the orbital output shafts 186a-186j. As previously mentioned, the rotary output shafts 176a-176j are concentrically disposed within the orbital output shafts 186a-186j. The square pitch of the ten orbital output shafts 186a-186j is identical to the square pitch of the tubes 4 mounted in the tubesheet 221 of a nuclear steam generator in order to permit the spindles 3a-3j to be simultaneously inserted into and operated within the open ends 219 of these tubes 4. However, in order to attain the desired square pitch between the orbital output shafts 186a-186j, gears having different radii, and hence different numbers of gear teeth, had to be used. Specifically, the drive gears 168 and 170 and the idler gears 174a-174c and 184a-184c of the lower and upper gear levels 162 and 164 each had thirty teeth, while the rotary output gears 172a-172j and the orbital output gears 182a-182j each had thirty-one teeth. This in turn prohibited a design wherein all of the gears on the same gear levels 162 or 164 could mutually intermesh without interference. As will be seen shortly, a solution to this problem was achieved by machining off the teeth of some of the gears on each level on either their top or bottom halves so that the teeth of some of the gears on each level would rotate over or under one another without intermeshing. The end result is the extremely compact output gearbox 160.

The gear train of the lower gear level 162 includes a rotary drive gear 168 which forms part of the previously mentioned output shaft 155 of the input rotary miter gear 154. All of the teeth of the rotary drive gear 168 are intact, as is indicated in FIG. 9. Rotary drive gear 168 drives rotary output gears 172a-172j, as well as three idler gears 174a-174c. Rotary output gear 172a has teeth only at its bottom half, while rotary output gears 172b, 172c and 172d have a full set of teeth on both their top and bottom halves. Rotary output gears 172e

and 172f include teeth only on their bottom halves, while rotary output gear 172g includes teeth only on its top half. Further, rotary output gear 172h includes teeth only on its bottom half, rotary output gear 172i includes teeth only on its top half, and rotary output gear 172j includes teeth only on its bottom half. Finally, idler gear 174a includes teeth only on its bottom half, idler gear 174b includes teeth only on its top half, and idler gear 174c includes teeth only on its bottom half.

As previously mentioned, if all of these rotary output gears 172a-172j and idler gears 174a-174c mutually intermeshed, the gear train in the lower gear level 162 could not run due to the mechanical interference caused by the fact that the drive and idler gears have thirty teeth, while the rotary output gears have thirty-one teeth. However, the technique of eliminating the gear teeth on either the top or bottom halves of some of these gears allows them to rotate adjacent one another without interference. Hence, the rotary drive gear, having full teeth, may simultaneously intermesh with and rotate surrounding gears 172c, 172d, 172g and 172h. Rotary output gear 172d, having full teeth, may in turn intermesh with and rotate idler gear 174c. However, if the teeth of idler gear 174c were allowed to intermesh with the teeth of the rotary output gear 172g, interference would result because rotary output gear 172 has an odd number of gear teeth which cannot simultaneously mesh with both the rotary drive gear 168 and the idler gear 174c. Hence, the removal of the gear teeth from the bottom of rotary output gear 172g and the top of idler gear 174c prevents such interference from occurring. Similarly, while idler gear 174a may simultaneously drive rotary output gears 172a, 172b and 172j without interference, such interference would occur if the teeth of this gear 174a were allowed to engage the teeth of rotary output gear 172i. Accordingly, idler gear 174a has teeth only on its bottom half, while rotary output gear 172i has teeth only on its top half. Idler gears 174b and 174c operate in exactly the same manner, and to avoid prolixity, a detailed description of the exact manner in which they intermesh with their surrounding gears without interference will not be given here. In closing, it should be noted that each of the rotary output gears 172a-172j concentrically surrounds a rotary output shaft 176a-176j which includes a square recess 178a-178j for receiving the square end 27 of the mandrel 5 of each of the peening spindles 3a-3j.

Like the lower gear level 162, the upper gear level 164 includes ten orbital output gears 182a-182j, each of which includes thirty-one teeth. These gears 182a-182j are journaled directly over the rotary output gears 172a-172j. The upper gear level likewise includes three idler gears 184a-184c having thirty teeth apiece which are journaled over the idler gears 174a-174c, the only difference being that idler gears 184a and 184b are on either side of the drive gear 170. To avoid interference within the upper level gear train formed by these gears, the gear teeth from either the top or bottom halves of some of the orbital output gears 182a-182j and idler gears 184a-184c are removed in precisely the same pattern described in detail with respect to the lower level gear train. It should be noted that the gear train in the lower gear level 162 is driven at 3,100 rpms, while the gear train in the upper gear level 164 is driven at about 15.5 rpms.

Turning now to FIGS. 1, 10 and 11, and the oscillatory drive assembly 200 of the multi-spindle rotopeening device 1, this drive assembly includes a frame 202

formed from rectangular top and bottom support plates 204 and 206. The corners of the support plates 204 and 206 are connected together by means of four angular leg members 208a-208d. The top support plate includes a guide plate 210 having an array of ten apertures 211a-211j for aligning and guiding the tapered end portions 32 of each of the peening spindles 3a-3j into the open ends 219 of the tubes 4 mounted in a tubesheet 221. Each of these apertures 211a-211j is flared at either end in order to render the apertures 211a-211j more effective in their spindle alignment and insertion function. Top support plate 204 further includes a pair of limit switches 213a, 213b for transmitting an electrical signal to a control system (not shown) indicative of when the frame 202 is correctly installed in abutting relationship against tubesheet 221. These switches are each connected in parallel to the control system, and a "correct installation" signal is generated only when the states of both the switches change. Finally, top support plate 204 includes a pair of expandable collets 215, 217 for mounting the top plate 204 in firm, abutting relationship against the underside of the tubesheet 221. Each of the expandable collets 215, 217 may be inserted into the open ends 219 of the tubes 204 and expanded therein in order to firmly secure the top plate 204 of the frame 202 in the abutting relationship illustrated in FIG. 10. The preferred embodiment utilizes a Camlock Model 1728E50G02 expandable collet manufactured by Westinghouse Electric Corporation of Pittsburgh, Pa. A further limit switch 207 is connected to angular leg member 208a which generates a signal whenever the rotary and orbital drive assembly 80 connected to the oscillatory drive assembly 200 attains its lowest position within frame 202.

The frame 202 of the oscillatory drive assembly 200 supports an indexing and reciprocating mechanism 225 which translates and reciprocates the rotary and orbital drive assembly 80 and the attached peening spindles 3a-3j relative to the tubesheet 221. This indexing and reciprocating mechanism 225 includes a rectangular saddle plate 227 having a bronze nut assembly 228a-228d mounted on each of its four corners. Each of these bronze nut assemblies 228a-228d includes Orlite® bronze nuts 229a-229d which are secured in the saddle plate 227 by means of bolt pairs 230a-230d. The saddle plate 227 is movably suspended by means of four threaded rods 232a-232d which are screwed through the bronze nuts 229a-229d of the bronze nut assemblies 228a-228d. The ends of each of these threaded rods 228a-228d are, in turn, journaled in the top plate 204 and bottom plate 206 of the frame 202 by means of top plate bearings 234a-234d and bottom plate bearings 236a-236d, respectively. The saddle plate 227 supports the rotary and orbital drive assembly 80 by means of a pair of U-shaped straps 238, 239 mounted on its underside. Hence, the rotary and oscillatory drive assembly 80 and its attached peening spindles 3a-3j will translate or reciprocate along the longitudinal axis of the frame 202 in "riding nut" fashion whenever the threaded rods 232a-232d are simultaneously rotated clockwise or counterclockwise.

To control the simultaneous rotation of the threaded rods 232a-232d, a rod rotating assembly 240 is provided which is best seen with respect to FIGS. 10 and 12. The rod rotating assembly 240 includes an electric motor 242 having an output shaft 244 for driving a drive pulley 246. The drive pulley 246 is coupled to four rod rotating pulleys 248a-248d by means of a flexible drive belt 250

having gear teeth on either side meshable with the gear teeth of the rotating pulleys 248a-248d. A motor mounting plate 252 is detachably connected over the drive pulley 246 to afford easy access to the rod rotating assembly 240. Finally, the rotatable rod 232b is also connected to the shaft 253 of an optical encoder 255 by means of a belt 257. Since each of the rod rotating pulleys 248 is identical in size and number of teeth, drive pulley 246 is capable of simultaneously rotating each of the threaded rods 232a-232d at the same angular speed. The optical encoder 255 generates electrical pulses indicative of the number of revolutions made by each of the rod rotating pulleys 248a-248d, and transmits these electrical pulses to the aforementioned control system. The control system is preferably formed from a Model III control manufactured by Aerotech-Unidex Corporation of Pittsburgh, Pa., although other types of two-axis controllers which are programmable from an integral keyboard may be used as well. The control system computes the longitudinal distance that the rotating, threaded rods 232a-232d are moving the peening spindles 3a-3j on the rotary and oscillatory assembly 80 by counting the net number of counterclockwise rotations made by the rod rotating gears 248a-248d, and multiplying the net number of these turns against the known pitch of the threads in the threaded rods 232a-232d. The control system starts the turn count whenever the rods 232a-232d pull the rotary and orbital drive assembly 80 into contact with the limit switch 207 located on the angular leg 208a of the frame 202. The control system is further connected to the D.C. power source of electric motor 242, and controls both the angular speed and the angular direction of the drive gear 246 attached to the output shaft 244 of this motor 242 by varying both the polarity and magnitude of the d.c. power voltage entering the motor 242. In the preferred embodiment, the computer circuit in the control system is programmed to (1) monitor rotational rpms of both the electric motors 84 and 242 of the rotary and orbital drive assembly 80 and oscillatory drive assembly 200, respectively; (2) verify the vertical displacement of the spindles 3a-3j, and (3) independently monitor the rotopeening time. Additionally, the program logic should provide for a deactuation of both motors 84 and 242 if one or the other stops for any reason. If the rotary and orbital drive assembly motor 84 should continue while the oscillatory drive motor 242 quits, the peening balls 18 could create areas of localized stress in the tubes 4 which would defeat the purpose of the peening operation. On the other hand, if the rotary and orbital drive assembly motor 84 should stop while the oscillatory drive motor 242 continues, the peening flappers 13a-13f may become damaged.

Specific Description of the Method of the Invention

In the first step of the method of the invention, the multi-spindle rotopeening device 1 is first mounted against the tubesheet 221 of a nuclear steam generator in the position illustrated in FIG. 10. Specifically, the operator of the device slides the expandable collets 215, 217 into the open ends of heat exchange tubes 4 which are adjacent the open ends of other tubes 4 which the operator desires to rotopeen. When the operator is confident that the top support plate 204 is firmly abutting against the lower surface of the tubesheet 221, he manually expands both of the expandable collets 215, 217 by rotating the knurled handles thereof. Next, the operator confirms that the top plate 204 is indeed flatly engaged

against the tubesheet 221 by checking the output of the two limit switches 213, 213*b*. A positive output from these switches confirms to the operator that the top plate 204 is indeed properly engaged in abutting relationship against the tubesheet 221.

When the top plate 204 is thus positioned, the various flared apertures 211*a*-211*j* of the guide plate 210 automatically come into registry with the open ends 10 of the heat exchange tubes 4 mounted in the tubesheet 221, as is illustrated in FIG. 10. Thus positioned, the multi-spindle rotopeening device 1 is ready to commence the peening of the tubes 4.

Electric motor 84 of the rotary and orbital drive assembly 80 is next actuated, which drives the mandrels 5 of each of the spindles 3*a*-3*j* at 30 rpms, and the housings 30 of each of these spindles stay essentially stationary. Next, the reversible motor 242 of the oscillatory drive assembly 150 is actuated in order to elevate the spindles 3*a*-3*j* slowly through the guide plate 210 in "riding nut" fashion. Motor 242 first elevates the spindles at a rate of about 0.25 inch per second, until all of the flappers 13*a*-13*l* are through the mouth 219 of the tube 4, whereupon the rate of vertical advance increases to 2 inches per second until the spindles 3*a*-3*j* are positioned in their upper index position. Because the peening flappers 13*a*-13*l* are rotating as they are being extended through their respective apertures 211*a*-211*j* in the guide plate 210, they will "feed" into the flared ends of these apertures 211*a*-211*j* smoothly and without binding.

As the indexing and reciprocating mechanism 225 lifts the peening spindles 3*a*-3*j* into their uppermost index position within the tubes 4, the optical encoder 255 generates a pulse with every rotation of the drive pulley 246 of the rod rotating assembly 240. These pulses are received and counted by the control system of the invention. The computer circuit of the control system momentarily switches off the reversible motor 242 which drives the indexing and reciprocating mechanism 225 of the oscillatory drive assembly after it counts a number of pulses which indicates that the spindles 3*a*-3*j* have achieved their uppermost index position. Thereafter, the computer circuit simultaneously orders the rotary and orbital drive motor to drive the mandrels 3*a*-3*j* at 3,100 rpms, and the reversible motor 242 to alternately rotate clockwise and counterclockwise so as to oscillate the spindles 3*a*-3*j* at a frequency of between 27 and 32 cycles per minute and an amplitude of approximately 0.65 inch within the tubes 4. Such an amplitude has been found to overlap the various helical paths which the peening balls 18 of the peening flappers 17*a*, 17*b* trace as they are rotated, orbited and oscillated within the tubes 4 so that the resulting peening pattern is uniform in intensity at all points. While other amplitudes may be used in connection with the peening spindles 3*a*-3*j*, such amplitudes should be chosen so that each longitudinal increment of the tube being peened is struck approximately the same number of times by the peening balls 18 of the flappers 13*a*-13*l*. Other oscillatory frequencies may be used instead of 27-32 cycles per minute; however, the oscillatory frequency should be chosen so that it is not a multiple of the orbital rpms in order to avoid a situation where the peening balls 18 impinge the inner wall of the tubes 4 along the same helical paths with each rotation of the cages 50 of the spindles 3*a*-3*j*. Such constructive interference between the orbital and oscillatory frequencies could create

areas of localized stress within the tube which could in turn defeat the purpose of the operation.

The flappers 13*a*-13*l* of each of the spindles 3*a*-3*j* are rotated and orbited at angular speeds of 3,100 and 15.5 rpms for an amount of time sufficient topeen the inner wall of the tubes to a peening intensity of approximately 10 A on the Almen scale. When the stand-off distance S between the inner edge of the flapper leaves 17*a*, 17*b* and the inner surface of the tubes 4 is 100 mils, the amount of time that the spindles 3*a*-3*j*peen the tubes in the upper index position is approximately four minutes. After this four minute time period has expired, the computer circuit of the control system lowers the peening spindles 3*a*-3*j* to a middle index position, and then oscillates these spindles in the manner previously described for an additional four minutes. After this second four minute time period has expired, the computer circuit lowers the spindles 3*a*-3*j* to a bottommost index position, and oscillates the spindles 3*a*-3*j* for a final four minutes. Thereafter, the computer circuit lowers the spindles back to the lowermost position illustrated in FIG. 10, thereby removing the spindles 3*a*-3*j* from the tubes 4 and depressing limit switch 207, which "zeros out" the computer's count of the pulses it has received from the optical encoder 256. The topmost, middle and bottommost index positions are chosen so that the resulting peening patterns are contiguous with one another in order to assure a uniform peening intensity along the longitudinal sections of the tubes 4 being peened.

The specific mandrel rpms and stand-off distances used in the method of the invention may vary, depending on such factors as the inner diameter of the tubes, the specific metallurgical properties of the materials forming the tubes, and the peening intensity desired. However, the data provided on the graphs of FIGS. 13 and 14 indicate that the foregoing mandrel rpms and stand-off distances are optimal when a peening intensity of 10 A is desired around the inner wall of a tube formed from Inconel 600. As used herein, the "optimal" combination of such peening parameters is that combination of mandrel rpms and flapper stand-off distance which most accurately results in a final peening intensity of approximately 10 A in the shortest manageable time. FIGS. 13 and 14 indicate that the optimum combination is indeed a mandrel angular speed of approximately 3,000 to 3,300 rpms at a stand-off distance of approximately 60 to 125 mils, over a time period of approximately four minutes at each index position.

Specifically, FIG. 14 illustrates the relationship between peening intensity over time for mandrel angular speeds of 2,500 rpms, 3,300 rpms and 4,300 rpms. In all cases, the curve formed by the interconnection of the small circles indicates that the test was run at a stand-off distance of 125 mils, while the graphs formed by the interconnection of squares, triangles and large circles indicate stand-off distances of 100 mils, 90 mils and 60 mils, respectively. While it is clear from the results of this graph that a mandrel rotational speed of 4,300 rpms can result in a peening intensity of 10 A very rapidly (i.e., in less than one minute), the near-vertical slope of these curves in the vicinity of 10 A also indicates that the accurate achievement of a 10 A peening intensity would be difficult, if not impossible. In other words, an under-peening or over-peening condition could easily result at this angular speed if the rotary and orbital drive assembly 80 were left on or turned off a few seconds too late or too soon. By contrast, while each one of the four

curves recorded for a mandrel angular speed of 2,500 rpms would seem to offer an extremely flat peening rate curve in the vicinity of a peening intensity of 10 A (assuming they were extrapolated over time), it is clear that a peening intensity of 10 A could be achieved only after an inordinate amount of time had expired.

From the foregoing discussion, it is clear that a mandrel angular speed of about 3,000 to 3,300 rpms at a stand-off distance between 60 and 125 mils offers the most desirable balance between the conflicting goals of accurate peening control versus minimum time. The peening intensity curves at each of these four stand-off distances are very flat in the vicinity of the desired peening intensity of 10 A, which indicates that accurate control of the final peening intensity may be easily achieved. Stated another way, the operation of the rotary and orbital drive assembly 80 a few seconds more or less than four minutes will not materially affect the resulting peening intensity to any great extent. Moreover, while the four minute time period required to achieve a peening intensity of 10 A is not as short as the one minute or less times which may be achieved at a mandrel speed of 4,300 rpms, it is at least a reasonable compromise in view of the significant amount of peening intensity control associated therewith.

While the graphs of FIG. 14 indicate that stand-off distances of between 60 and 125 mils may be used, the distances affording a maximum amount of flatness in the vicinity of a 10A peening intensity are the most preferred due to the paramount importance of peening control. While the graph indicates that stand-off distances of both 60 mils and 100 mils offer extremely flat peening intensity curves in the 10A region, the 100 mils stand-off distance is preferred since it results in less wear to the flap-receiving round edge 58 of the cage 50 of the spindles 3a-3j.

We claim as our invention:

1. A peening spindle for rotopeening the inside wall of a conduit, comprising:
 - (a) a rigid, rotatable and reciprocable housing having a substantially continuous outer surface with an opening along its side, said housing being insertable within the conduit;
 - (b) a mandrel having at least one peening means connected thereto, and
 - (c) bearing means located within and supported by the housing for rotatably mounting the mandrel within the housing off-center relative to the longitudinal axis of the housing with the peening means in alignment with the side opening so that said peening means rotates, reciprocates, and orbits within the conduit when said mandrel is rotated and said housing is rotated and reciprocated.
2. The apparatus of claim 1, wherein said bearing means for rotatably mounting the mandrel within the housing includes at least one bore which is substantially parallel to but radially displaced from said longitudinal axis of said housing for journalling said mandrel in said off-center manner.
3. The apparatus of claim 1, wherein said bearing means for rotatably mounting the mandrel within the housing also maintains a selected distance between the peening means and the inner wall of the conduit as the peening means orbits and reciprocates within the conduit.
4. The apparatus of claim 1, wherein said bearing means for rotatably mounting the mandrel within the conduit also prevents the rotatable and reciprocable

housing from frictionally engaging the inner wall of the conduit.

5. The apparatus of claim 1, wherein said peening means includes a plurality of flappers mounted onto the mandrel, each of which is angularly displaced from the flappers immediately adjacent thereto relative to the axis of rotation of said mandrel.

6. The apparatus of claim 1, wherein said peening means includes a plurality of flappers mounted onto the mandrel, each of which is longitudinally spaced from the flappers immediately adjacent thereto.

7. The apparatus of claim 1, wherein said opening of said housing is a cage means formed from an open section and a ligament, and wherein said peening means rotates within said cage means.

8. The apparatus of claim 7, wherein said bearing means for rotatably mounting the mandrel within the conduit includes first and second bearing means positioned on either side of the cage means for journalling the peening means within the cage means.

9. The apparatus of claim 1, wherein said mandrel includes a rigid portion for holding said peening means, and a flexible portion for coupling the rigid portion to a drive means.

10. The apparatus of claim 7, wherein the edge of said ligament which receives the peening means is rounded.

11. A peening spindle for rotopeening the inside wall of a conduit, comprising:

- (a) a rigid, rotatable and reciprocable housing having a substantially continuous outer surface with an opening along its side;
- (b) a mandrel having at least one peening flapper mounted thereon, and
- (c) bearing means located within the housing for rotatably mounting the mandrel within the housing substantially parallel to but radially displaced from the longitudinal axis of the housing and with the peening flapper in alignment with the open section so that the peening flapper rotates and orbits within the conduit when the mandrel is rotated and the housing is rotated and reciprocated, wherein said bearing means includes first and second bearings positioned within said housing on either side of said opening.

12. The apparatus of claim 11, wherein each of said bearings positioned on either side of said opening includes a bore which is substantially parallel to but radially displaced from the longitudinal axis of the housing for journalling the section of the mandrel supporting the peening flapper within said housing.

13. The apparatus of claim 11, wherein said first and second bearings prevent the outer surface of the housing from frictionally engaging the inner wall of the conduit as said housing rotates and reciprocates within the conduit.

14. The apparatus of claim 13, wherein each of said bearings includes at least one portion formed from a self-lubricating material which extends through the housing for engagement with the inner wall of the conduit to prevent the outer surface of the housing from frictionally engaging the inner wall of the conduit as said housing rotates and reciprocates within the conduit.

15. The apparatus of claim 11, wherein said mandrel includes a plurality of flappers, each of which is angularly displaced from the flappers immediately adjacent thereto relative to the axis of rotation of the mandrel.

16. The apparatus of claim 11, wherein said mandrel includes a plurality of flappers of substantially uniform width, each of which is longitudinally spaced from the flappers immediately adjacent thereto by a distance approximately equal to the width of the flappers.

17. The apparatus of claim 12, wherein said opening in said housing forms a cage means having a ligament for both maintaining the bores of said first and second bearings in alignment, and for maintaining the integrity of the housing.

18. The apparatus of claim 17, wherein said ligament of said cage means includes a cavity having a spiral-shaped cross-section for minimizing the peening action against the ligament, and for guiding the flapper into a whipping motion against the inner wall of the conduit.

19. The apparatus of claim 17, wherein the edge of the ligament which receives the flapper is rounded in order to reduce the amount of peening contact between said edge and the rotating peening flapper.

20. The apparatus of claim 11, wherein the distal end of the housing is tapered to facilitate the insertion of the housing into said conduit.

21. A peening spindle for rotopeening the inside wall of a tube, comprising:

(a) a rigid, rotatable and reciprocable housing having a tapered distal end for facilitating the insertion of the housing into a tube and a cage means formed from an open section in the wall of the housing, and a ligament;

(b) a mandrel disposed within the housing which includes a plurality of peening flappers mounted on a longitudinal section thereof, and

(c) first and second bearings located within and supported by the housing and positioned on either side of the cage means for rotatably mounting said longitudinal, flapper-bearing section of the mandrel across the cage means of the housing in an off-center orientation relative to the longitudinal axis of the spindle so that the flappers rotate and orbit within the tube when the mandrel and housing are rotated with their edges whippingly striking the inside wall of the tube through said open section of said cage means in said housing.

22. The apparatus of claim 21, wherein the maximum diameter of said bearings is greater than the maximum diameter of said housing, and said bearings engage the inside wall of the tube in a running fit when said housing rotates and maintains said longitudinal, flapper-bearing section of said mandrel a selected radial distance from the innerall of the tube.

23. The apparatus of claim 22, wherein said bearings are formed from a self-lubricating substance.

24. The apparatus of claim 21, wherein each of said peening flappers is approximately the same width, and wherein each of said flappers is orthogonally disposed to the adjacent flappers, and wherein each flapper is

spaced from the adjacent flappers by a distance equal to about one flap width.

25. A peening spindle for rotopeening the inside wall of a tube, comprising:

(a) a rigid, rotatable, and reciprocable housing having a cage means formed from an open section in the side wall of the housing, and a ligament, wherein the exterior surface of the housing is otherwise substantially closed;

(b) a mandrel disposed within said housing which includes a plurality of peening flappers mounted on a longitudinal section thereof, wherein each of said flappers is angularly non-aligned with the flappers immediately adjacent thereto, and

(c) first and second bearings located within said housing and positioned on either side of the cage means of the housing for

(i) rotatably mounting said longitudinal, flapper-bearing section of the mandrel across the cage means of the housing in an off-center orientation relative to the longitudinal axis of the spindle housing so that the flappers rotate and orbit within the tube when the mandrel is rotated and the housing is rotated and reciprocated, and for (ii) maintaining a selected radial distance between the longitudinal, flapper-bearing section of the mandrel and the inner wall of the tube.

26. The apparatus of claim 25, wherein the maximum diameter of said bearings is greater than the maximum diameter of said housing, and said bearings engage the inside wall of the tube in a running fit when said housing rotates and maintains said longitudinal, flapper-bearing section of said mandrel a selected radial distance from the innerall of the tube.

27. The apparatus of claim 26, wherein said bearings are formed from a self-lubricating substance.

28. A peening apparatus for rotopeening the inside wall of a conduit, comprising:

(a) rigid, rotatable housing having a cage means formed from an open section in the housing and a ligament;

(b) a mandrel having at least one peening flapper mounted thereon, and

(c) first and second bearings located within the housing on either side of the cage for rotatably mounting the mandrel within the housing with the peening flapper in alignment with the cage, each of said bearings including a bore which is substantially parallel to but radially displaced from the longitudinal axis of the housing for receiving said mandrel,

wherein said ligament of said cage means includes a cavity having a spiral-shaped cross-section for minimizing the peening action against the ligament, and for guiding the flapper into a whipping motion against the inner wall of the conduit.

* * * * *

60

65